



ModMKFMT0.01BA 04/2013

Big challenges
Great solutions

FREZITE, A HISTORY OF SOUNDNESS AND INNOVATION

Working for the highly competitive professional and industrial segments, Frezite has achieved its growth in sound, sustainable fashion since its foundation in 1978. The company started its activity with the production of high-precision tools for the wood, plastics, composite materials and metals transformation industries and sectors.

The opportunities generated by the surge of the automobile and aerospace sectors have led to the automation of the Metal Division and the creation of the **FMT – Tooling Systems brand**.

With head offices based in Portugal and strongly geared towards internationalisation, the Frezite Group already has a consolidated branch network. Developing engineering solutions for different markets, Frezite has been extending its field of action to new operating areas.

FREZITE Group





The commitment to innovation and excellence means that the Frezite Group and its products and technology can currently be found in over 50 countries spread around five continents.



A SOLID, GLOBAL PRESENCE

2012

Annual turnover

2013

Annual turnover expected



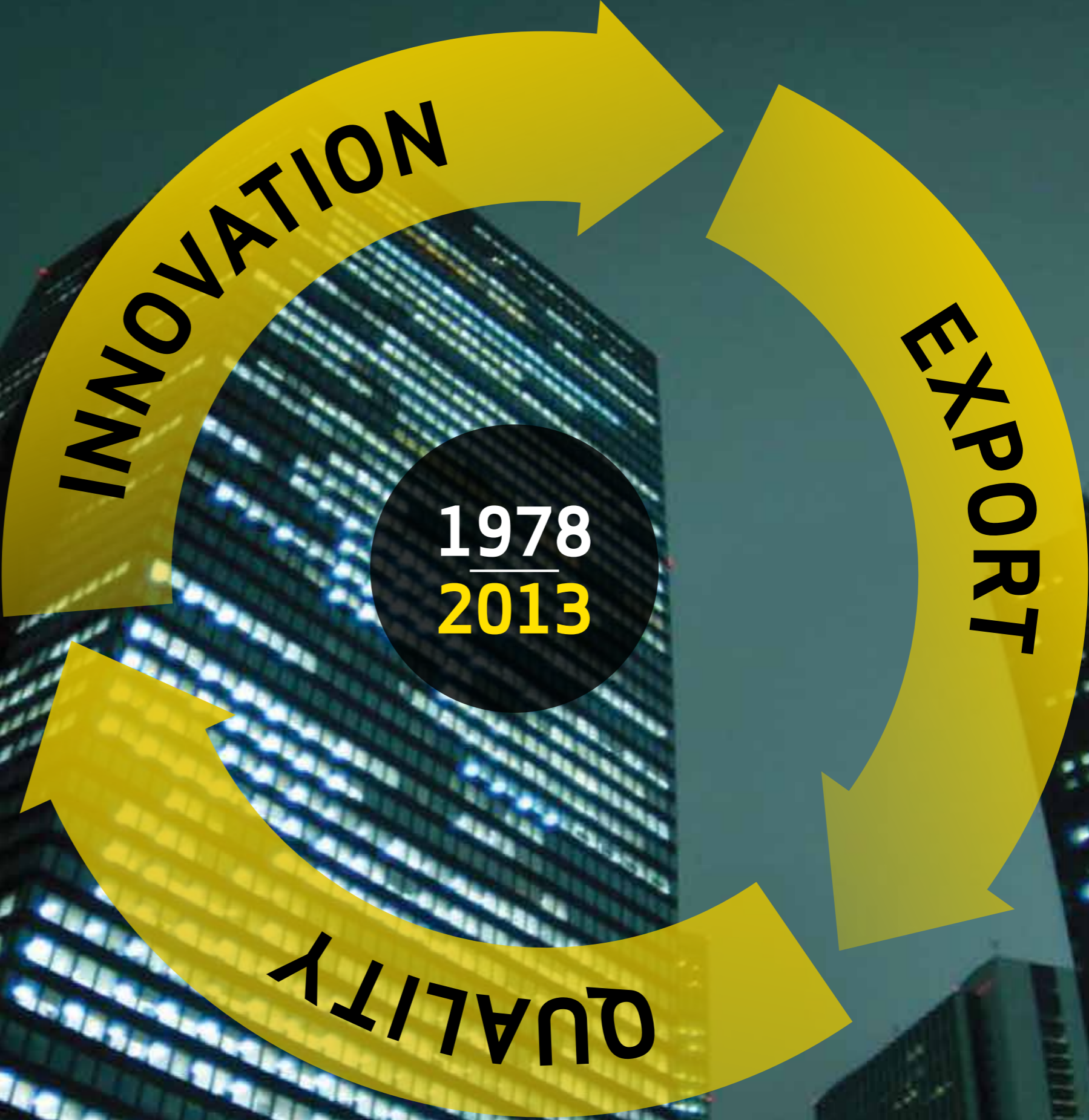
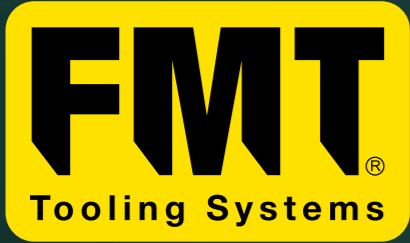

A touch of innovation based

on experience

MISSION

“TO BE AN ORGANIZATION
RECOGNIZED FOR ITS
EFFICIENCY IN MAINTAINING
AND CREATING VALUE.”

VISION

“TECHNOLOGY DEVELOPMENT
FOR SUSTAINABLE
IMPROVEMENT OF
QUALITY OF LIFE.”

VALUES

“INTEGRITY, TEAM SPIRIT AND INNOVATION.”

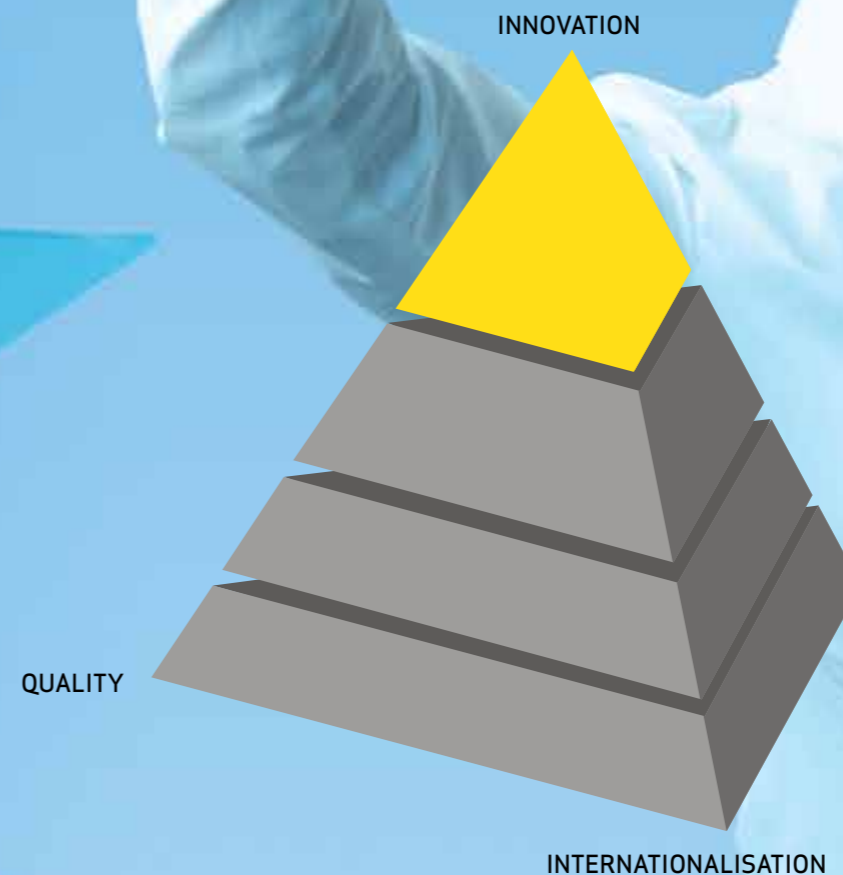

INDUSTRIES/MARKETS



AUTOMOBILE

AERONAUTICS

ELECTRONIC

MEDICAL

MOULDING

VALVES

PHILOSOPHY



Continued investment in the latest machinery technologies

Local support and service for all product

Commitment to research and development

Investment in expertise to support Key User Partnerships

FREZITE Group



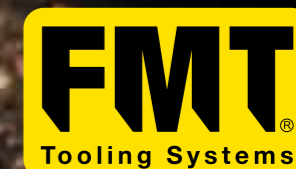

RESEARCH & DEVELOPMENT (CENTRE)

Internal test centre for new cutting tool designs.

Setting up of machining demonstrations for customers.

Troubleshooting of machining problems.

Development of new machining processes and internal knowledge.

The Power of Engineering



FMT 7 Advantages

Ideal Partners

Easy to Work With

Dynamic Team



**Enlarged
portfolio**

**Research
& Development**

**Focus
on Performance**

**Global
Presence**



Backed up by the great experience of its engineers in designing high-quality cutting tools – in standard products and customized solutions – Frezite's Metal Division has become more independent and now works with the FMT – Tooling Systems brand.

Geared up for any challenge, FMT adopts state-of-the-art working concepts, producing innovative tooling systems developed in line with the requirements of each customer.

The company has a Research and Development Centre at which it tests better adjusted solutions to ensure the best performance and returns.

Particularly geared towards meet the needs of the following industries: Automobile, Aeronautics, Moulds, Medical (Instrumental), Electronics, Equipment etc., the FMT brand offers the markets 7 advantages which set it apart.



AERONAUTICS INDUSTRY

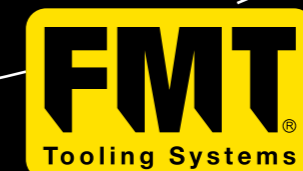

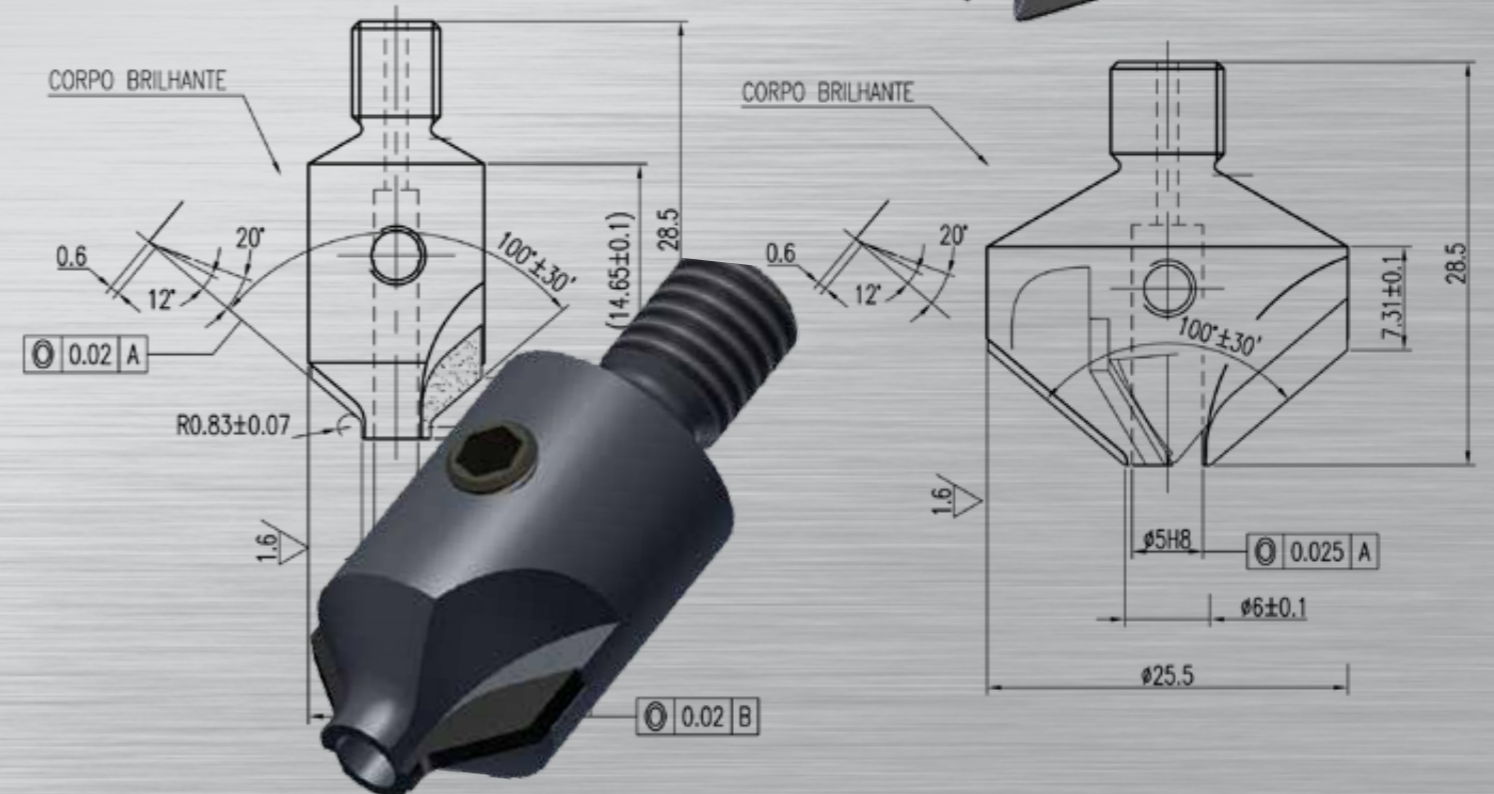
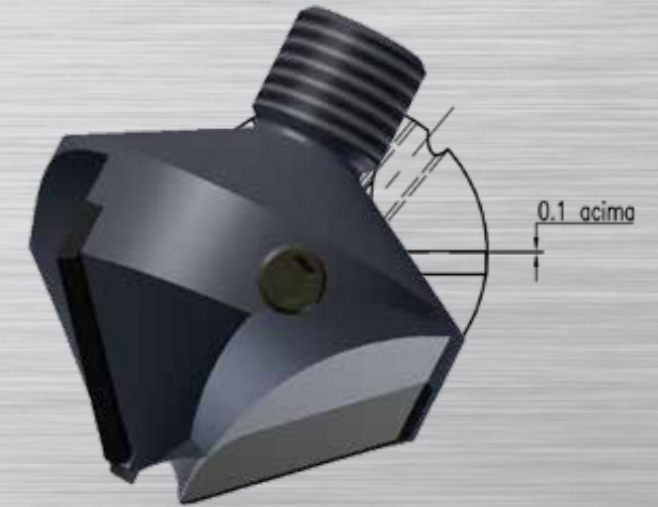
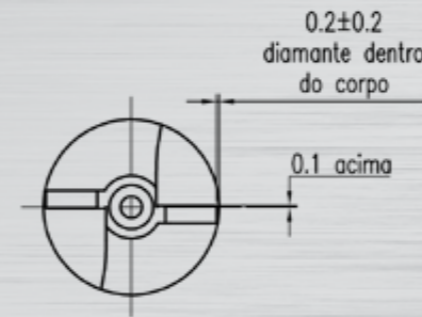
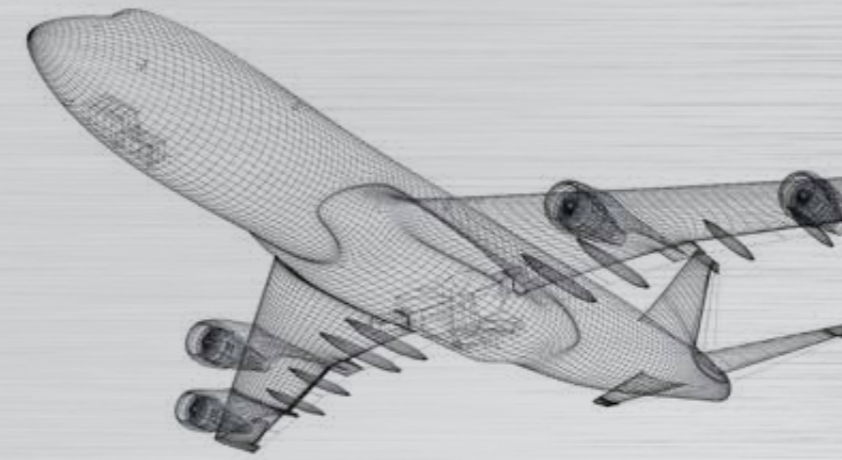

COUNTERSINKS PCD · CARBIDE

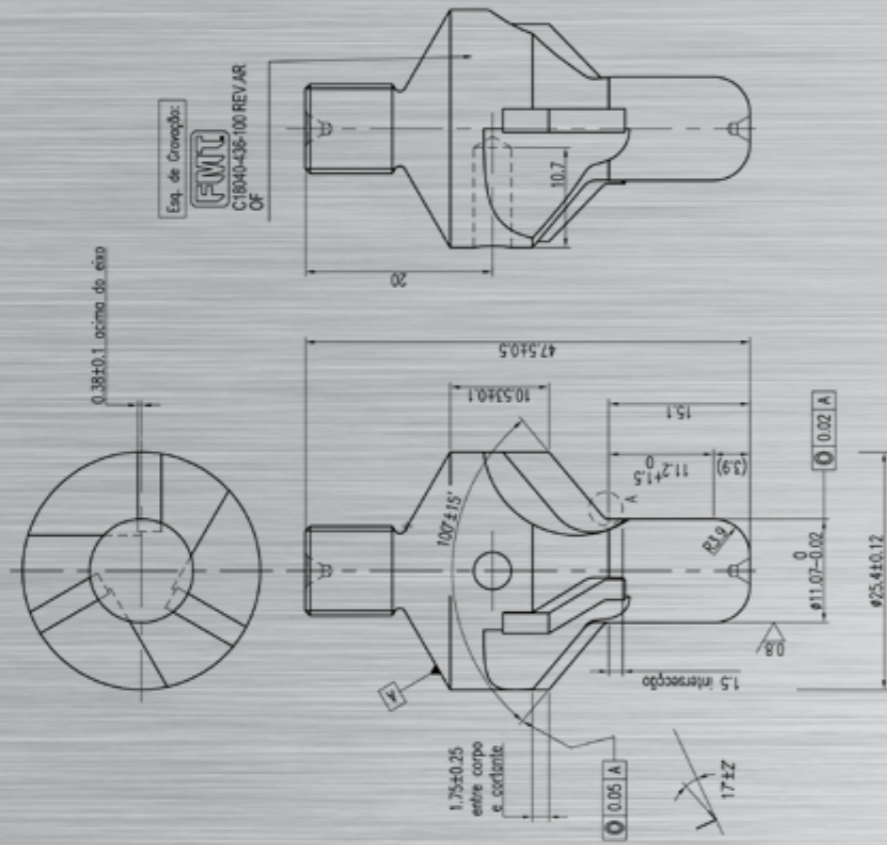

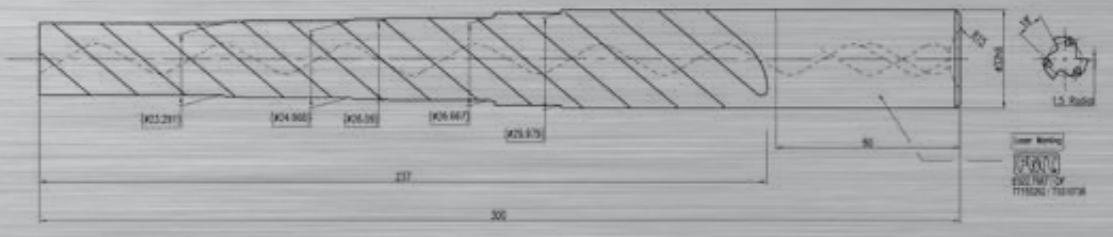
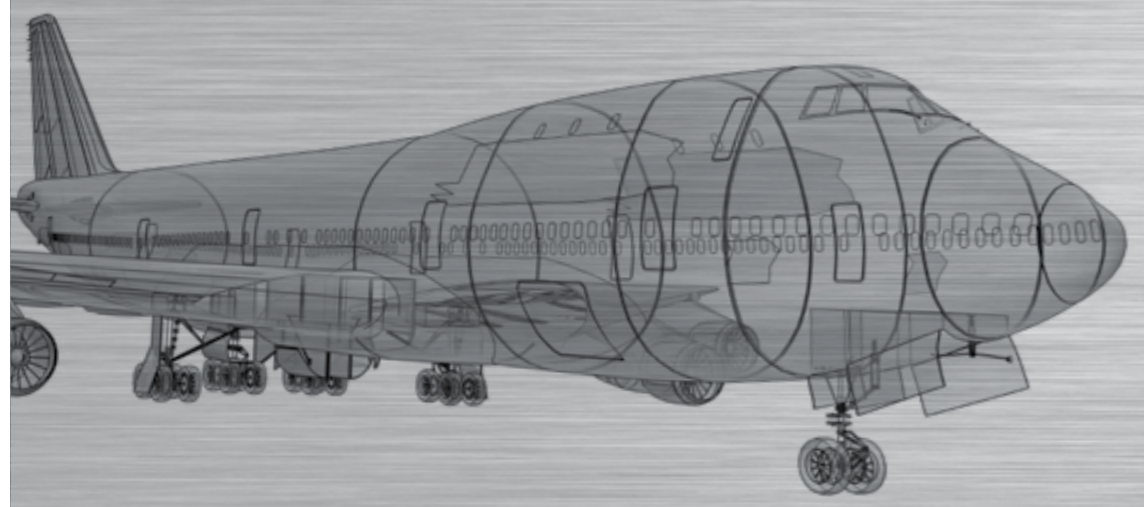
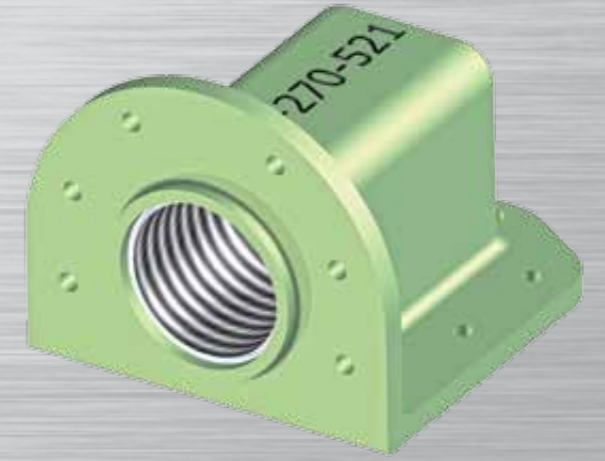
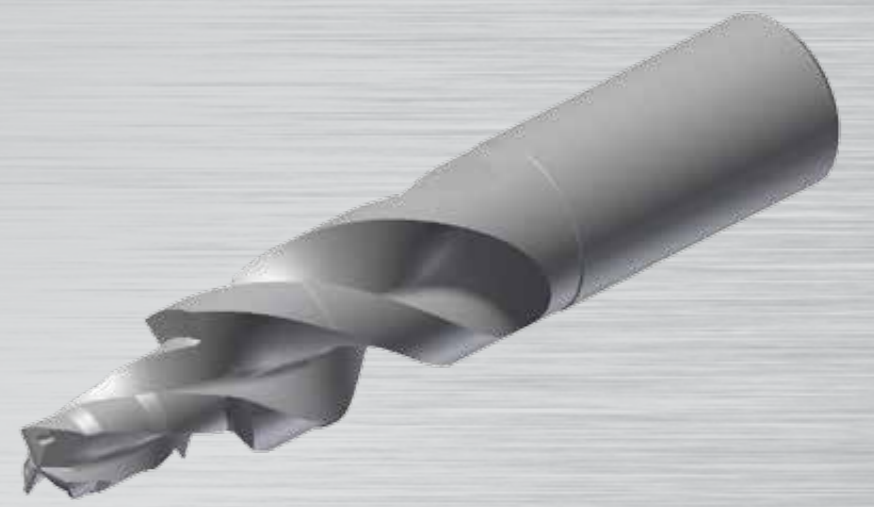
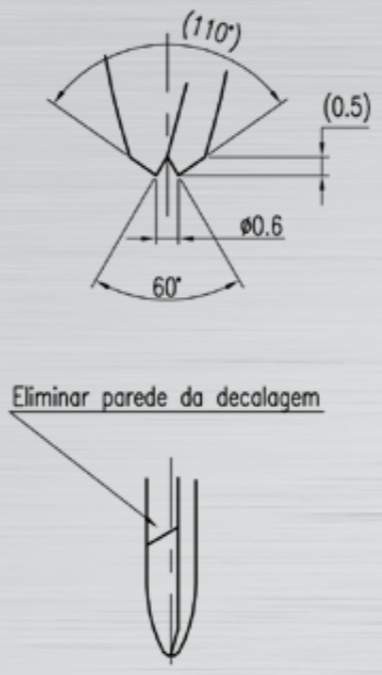
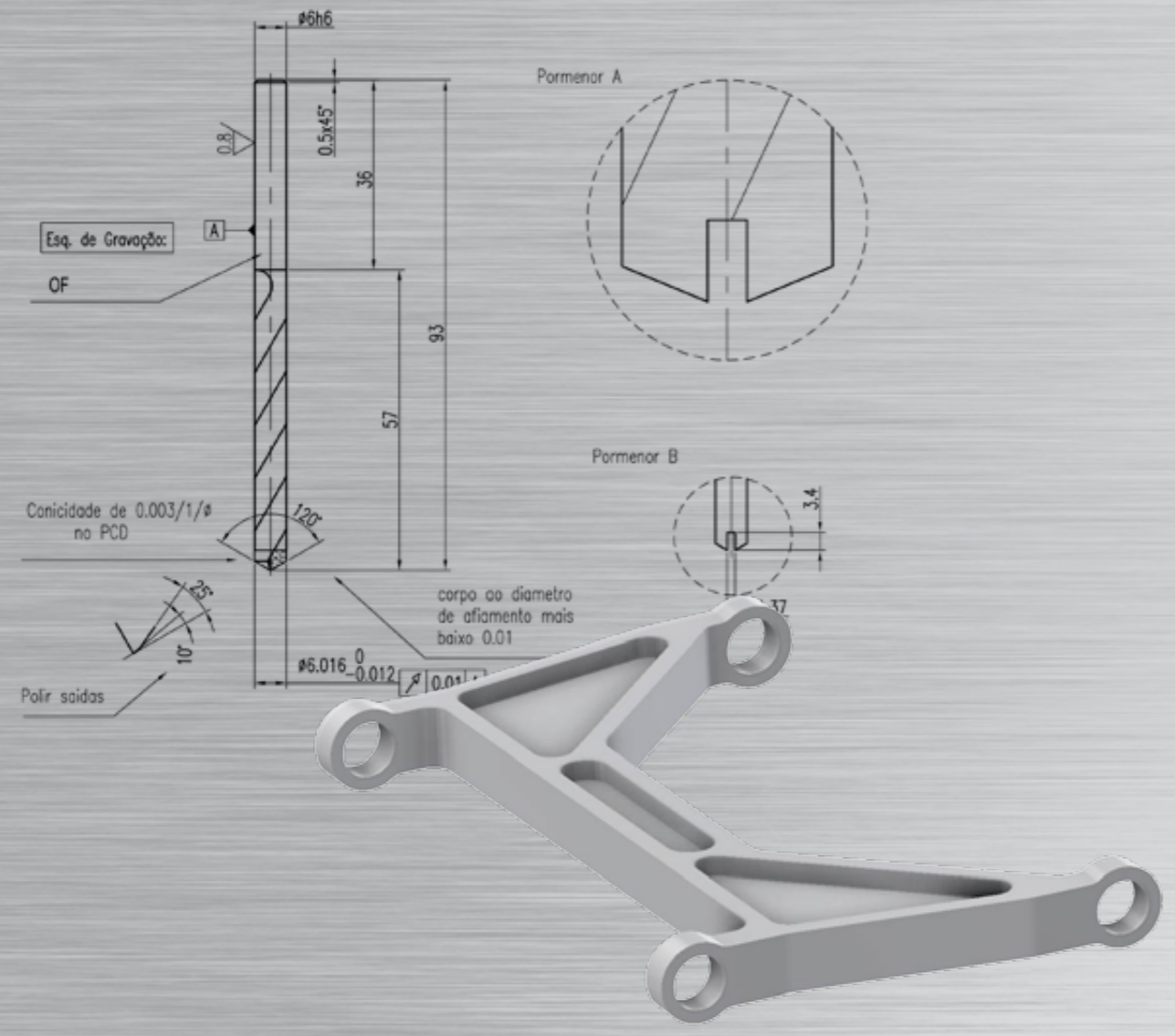

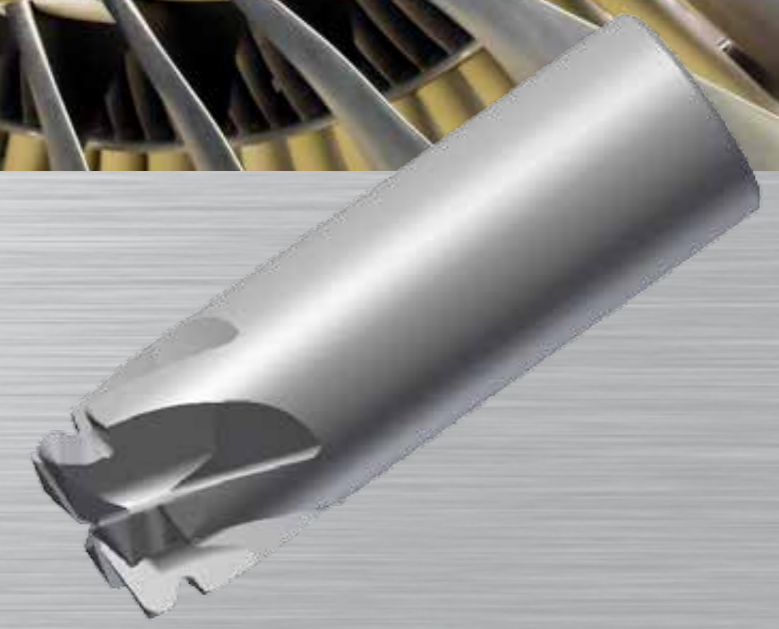
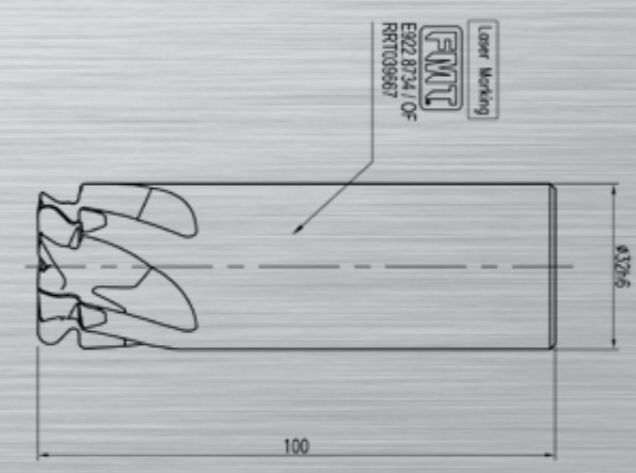
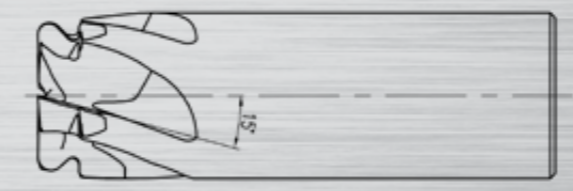
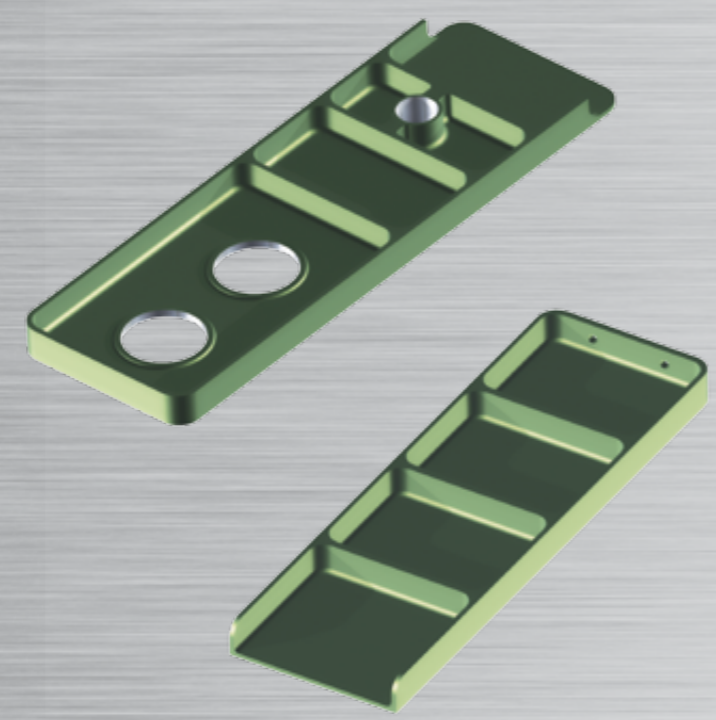
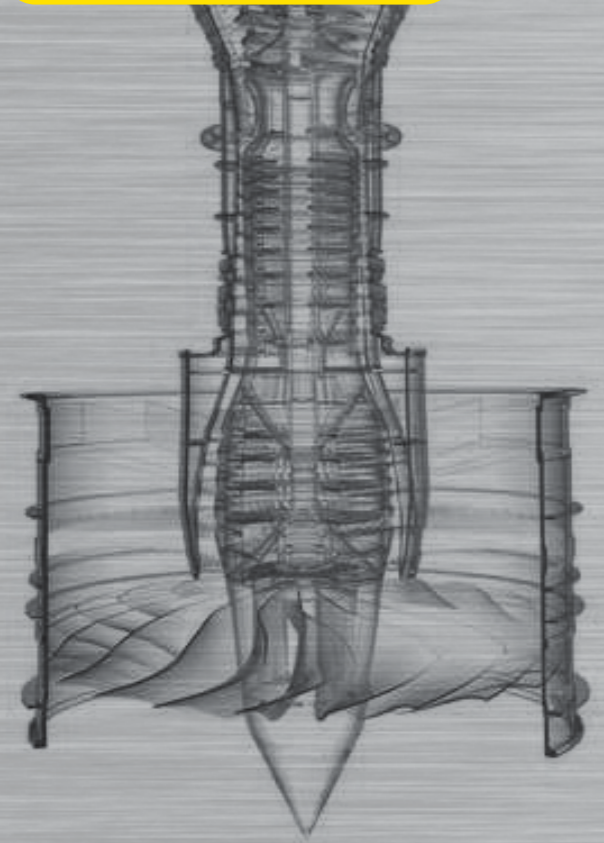

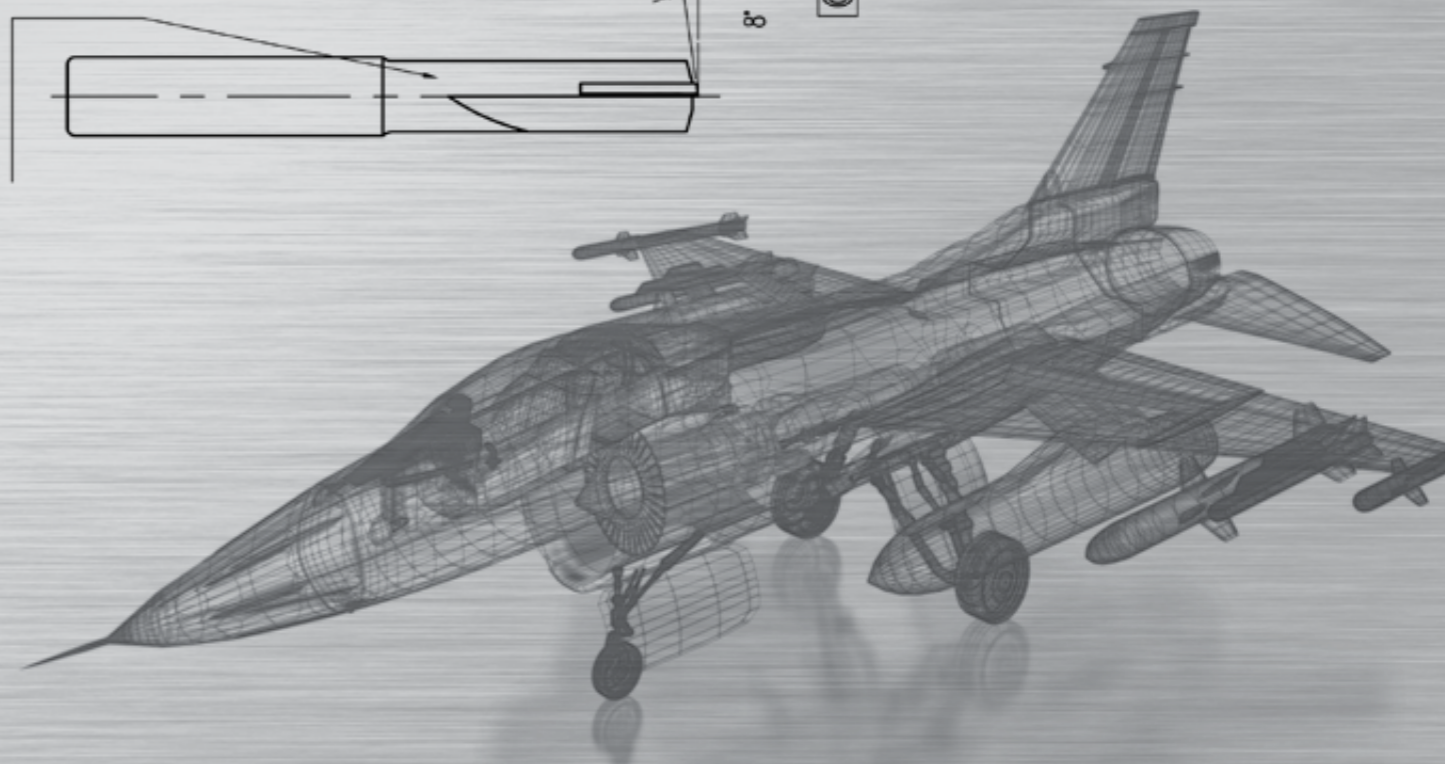
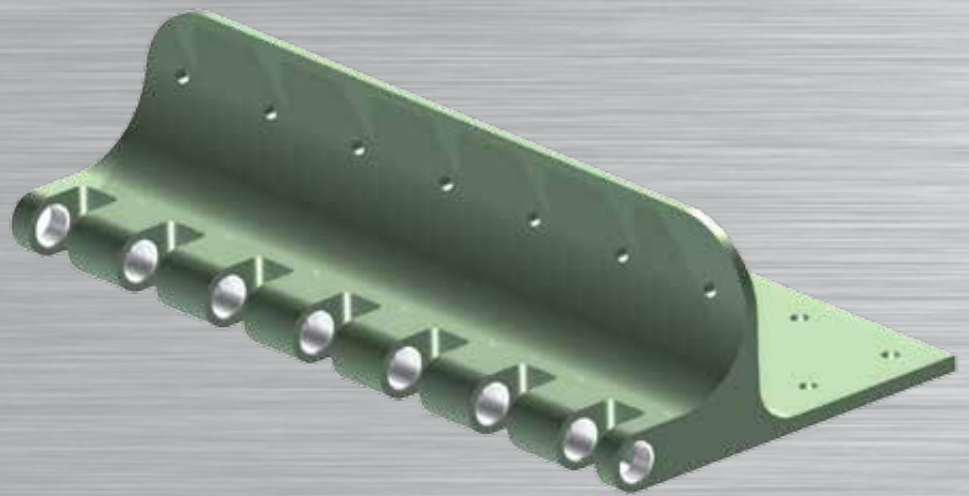
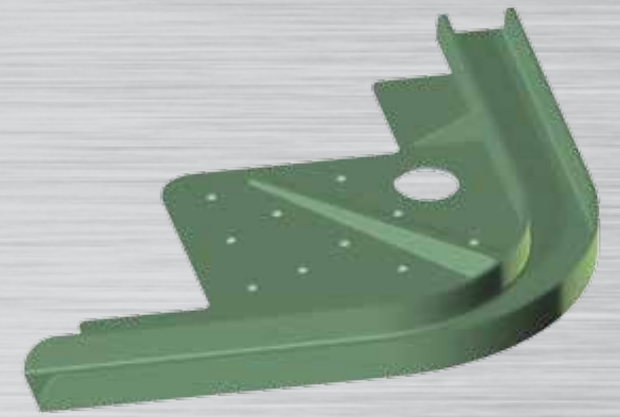
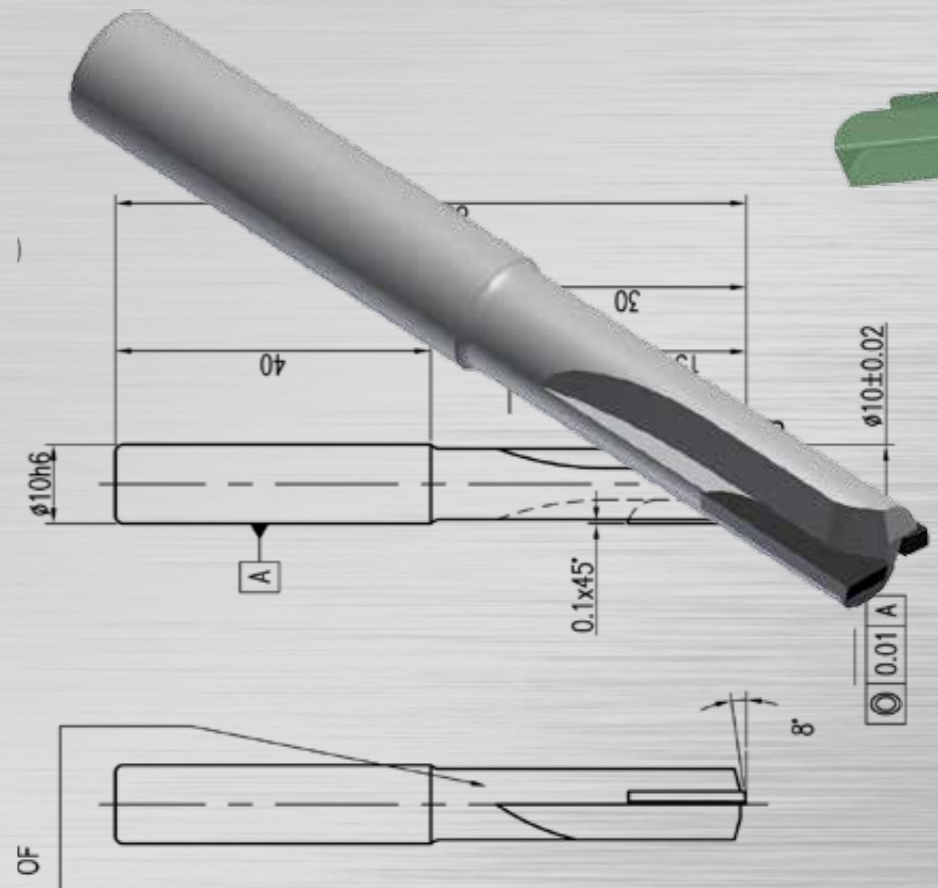
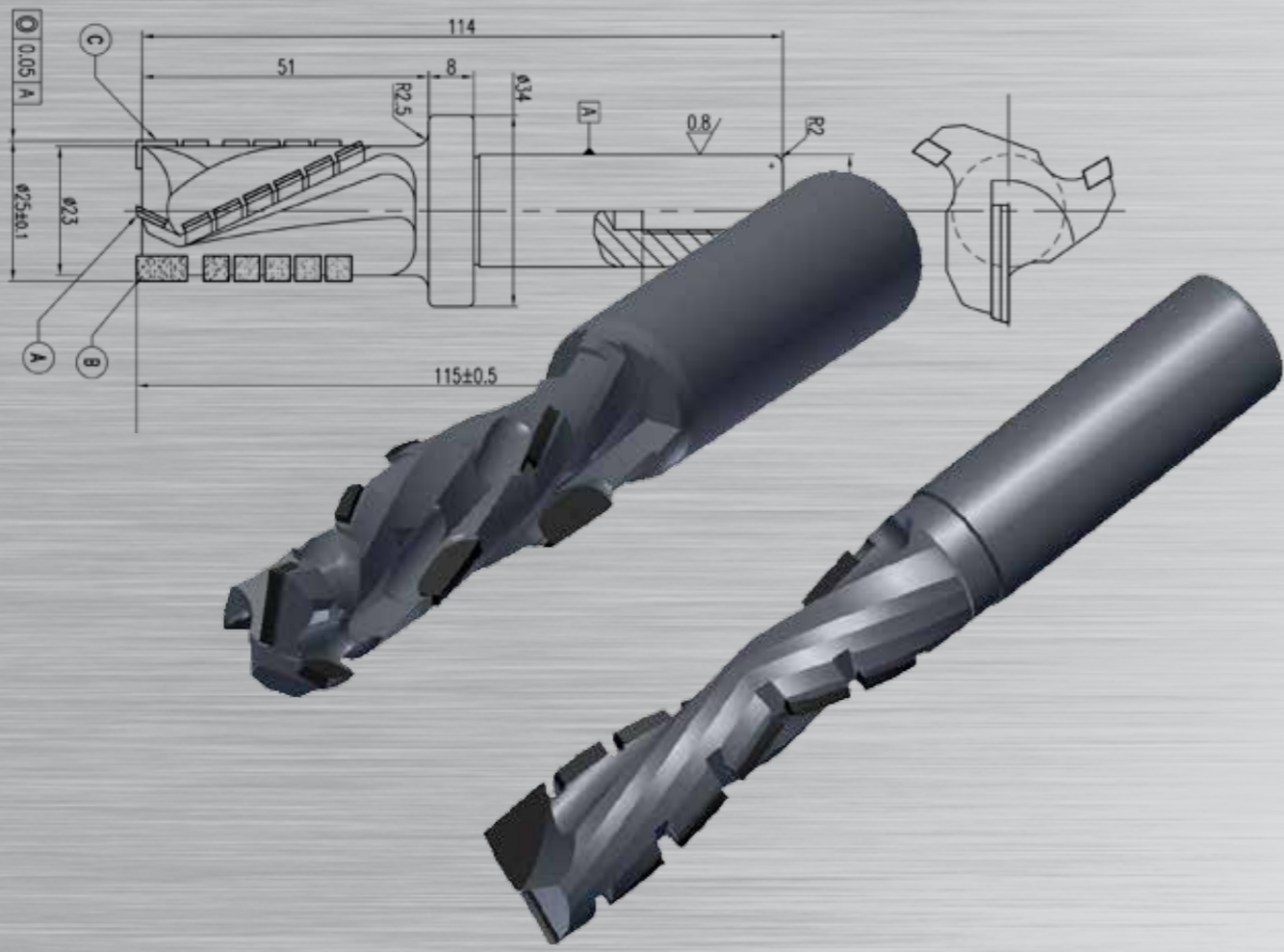

R&D

NEW DEVELOPMENT

THE EFFECTIVENESS
OF THE SOLUTIONS
PRESENTED BY FMT
IS AN ADDED BONUS
FOR THE CUSTOMER.

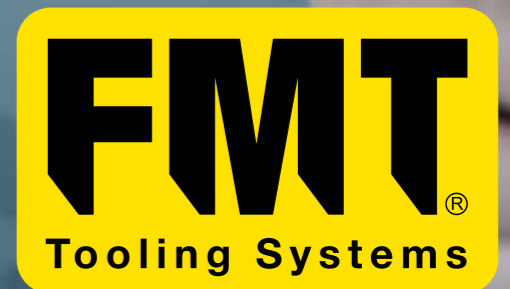

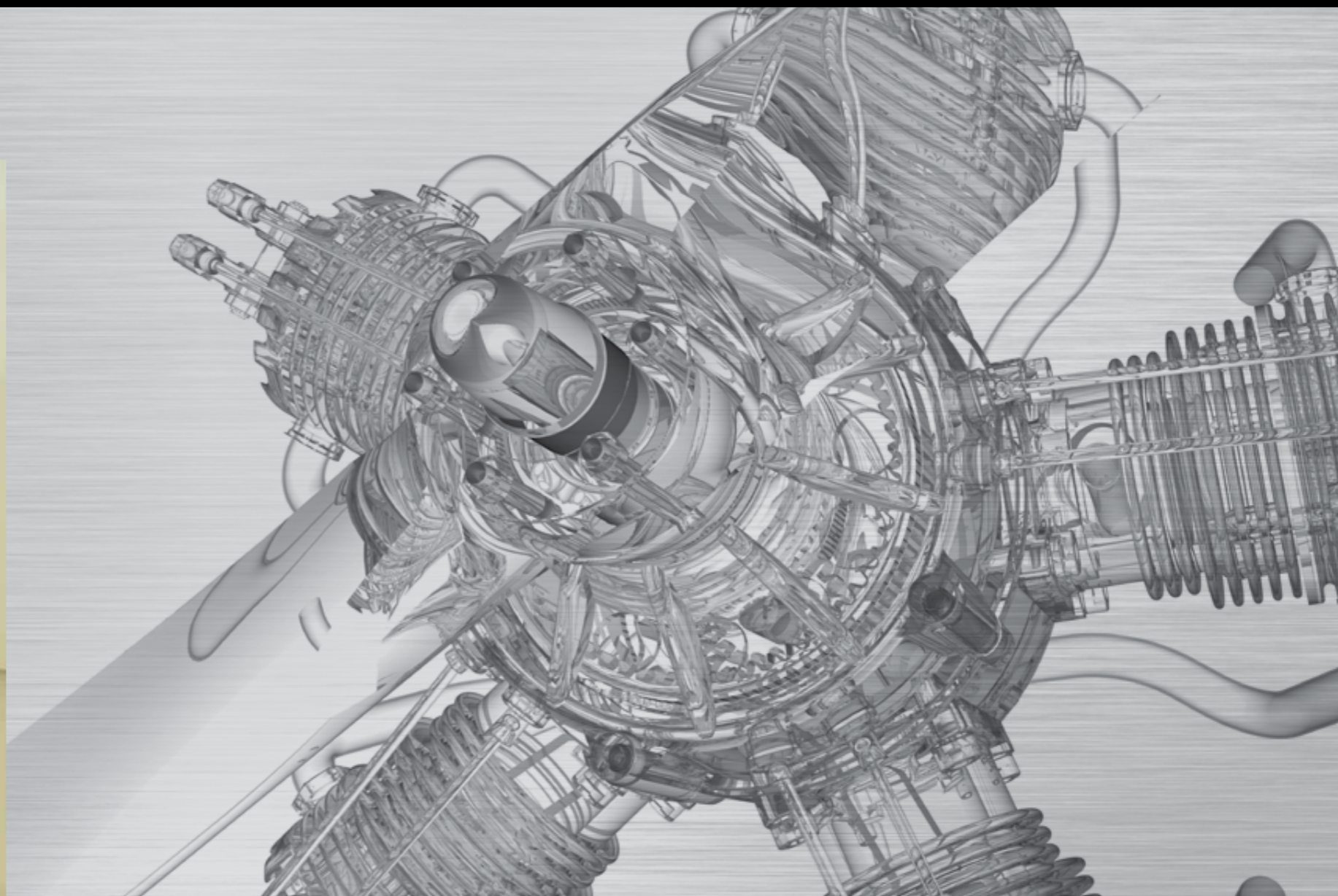

BY **CUTTING** YOUR
BUSINESS OPERATING
COSTS, WE **INCREASE** YOUR
PRODUCTIVITY.



“PINEAPPLE”

ADVANTAGES

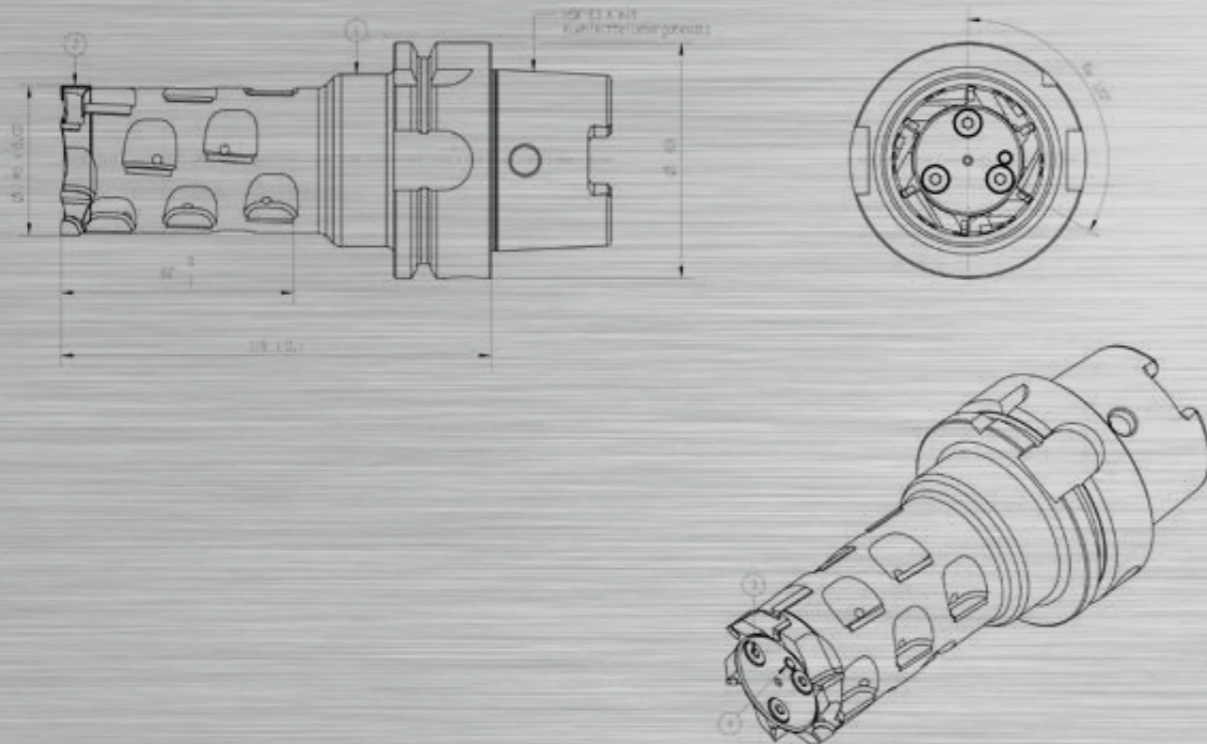
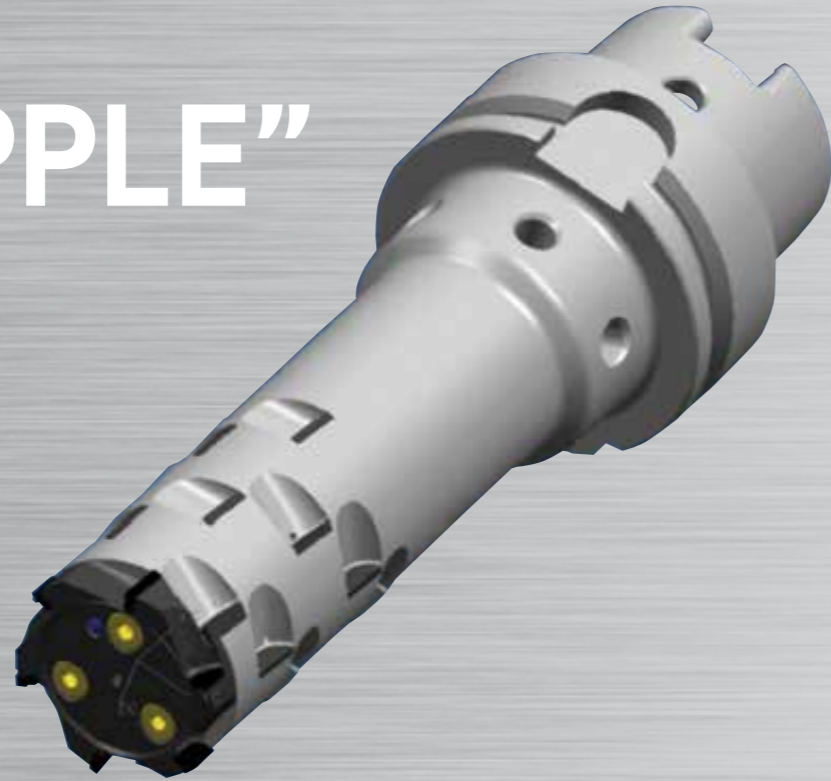

- Indexable main cutting edges (biggest abrasive wear)
- More affordable retiping costs
- Higher and optimized working performance as “Monoblock Milling Cutters”
- Higher productivity with higher feeds
- For roughing and finishing operations
- Higher system and exchanging accuracy
- Increased life time due to longer cutting inserts length
- Lower “Tool tourism”
- Lower storage costs





We turn challenges into technologies for the future.

FREZITE Group

PT Head Office:
FREZIGEST, SGPS, SA
Rua do Vau, 173 · Apartado 134
4786-909 Trofa
T. +351 252 400 360
F. +351 252 417 254
www.frezitegroup.com

PT FREZITE – Ferramentas de Corte, SA
Rua do Vau, 173 · Apartado 134
4786-909 Trofa
T. +351 252 400 360
F. +351 252 417 254
info@frezite.com
www.frezite.com

PT FREZITE – Ferramentas de Corte, SA (FMT)
Rua do Vau, 201 · Apartado 134
4786-909 Trofa
T. +351 252 400 360
F. +351 252 417 279
info@fmttooling.com
www.fmttooling.com

PT FREZITE – Equipamentos Energéticos
& Ambiente, Lda.
Rua do Vau, 323 · Apartado 134
4786-909 Trofa
T. +351 252 400 360
F. +351 252 401 014
energia@frezite.com
www.energia.frezite.com

PT FREZITE – Ferramentas de Corte, SA
(MF Metal)
Rua do Vau, 201 · Apartado 134
4786-909 Trofa
T. +351 252 103 277
F. +351 252 103 278
pedidos@mfmetal.net
www.mfmetal.net



ES FREZITE – Herramientas de Corte, SL
Polígono Ind. Virgen de la Salud, 8-A
P.O. Box 78
46950 Xirivella (Valencia)
T. +34 963 135 131
F. +34 963 796 810
info.es@frezite.com
www.frezite.com

ES Frezite Metal Tooling, SL
Polígono Ind. Virgen de la Salud, 8-A
P.O. Box 78
46950 Xirivella (Valencia)
T. +34 686 417 613
F. +34 963 134 484
info.es@fmttooling.com
www.fmttooling.com

BR FREZITE – Ferramentas de Corte, Ltda.
Rua Otto Emilio Beckert, 85-C
Boehmerwald · São Bento do Sul
SC CEP: 89287-665
T. +55 (47) 3635 2065/66
F. +55 (47) 3635 2067
comercial.brasil@frezite.com
www.frezite.com.br

FI Teratoimitus Salonen Oy
Vipusenkatu 17
15230 Lahti
T. +358 207 999 862
F. +358 207 999 868
jarmo.lehtinen@teratoimitus.fi
www.teratoimitus.fi

CZ FREZITE, sro
Ul. Textilni
506 01 Jičín
Czech Republic
T. +420 491 513 97- 0/1/2/3
obchod@frezite.cz
www.frezite.cz

DE FMT – Frezite Metal Tooling, GmbH
Lange Straße 66
72336 Balingen
T. +49 7433 / 99741-0
F. +49 7433 / 99741-25
info.de@fmttooling.de
www.fmttooling.com

UK Frezite Metal Tooling (UK) LTD
14B Orgreave Close
Handsworth Industrial Estate
Handsworth Sheffield S13 9 NP
T. +44 (0) 1142 693803
F. +44 (0) 1142 540523
enquiries@fmttooling.co.uk
www.fmttooling.co.uk

RO FMT Romania
Calea Turzii, nr 227, Ap 55
Cluj Napoca, Romania
T. +40 731 894 550
info.ro@fmttooling.com
www.fmttooling.com

PL FMT Tooling Systems Sp. z o.o.
ul. Klimasa 4
50-515 Wroclaw
T. +48 71 3907571
F. +48 71 3907571
bau@fmttooling.pl
www.fmttooling.pl

MX Frezite Metal Tooling S. de R.L. de C.V.
Calle 16 Sur No. 4312-101
Col. Anzures, Puebla, Pue. C.P. 72530
T. +52 (222) 2 454 875
info.mx@fmttooling.com
www.fmttooling.com