

cmc

Mod.MKFMT1.021A 08/2013

Big challenges,
Great solutions!

GEARBOX

www.fmttooling.com

FREZITE Group

FREZITE, A HISTORY OF SOUNDNESS AND INNOVATION

Working for the highly competitive professional and industrial segments, Frezite has achieved its growth in sound, sustainable fashion since its foundation in 1978. The company started its activity with the production of high-precision tools for the wood, plastics, composite materials and metals transformation industries and sectors.

The opportunities generated by the surge of the automobile and aerospace sectors have led to the automation of the Metal Division and the creation of the **FMT – Tooling Systems brand**.

With head offices based in Portugal and strongly geared towards internationalisation, the Frezite Group already has a consolidated branch network. Developing engineering solutions for different markets, Frezite has been extending its field of action to new operating areas.

FREZITE Group





Chairman
FREZITE GROUP
José Manuel Fernandes
jmf@frezite.com



CEO
FREZITE GROUP
Tiago Fernandes
tiago.fernandes@frezite.com



CFO
FREZITE GROUP
Luís Liz
luis.liz@frezite.com



General Manager
Metal Division
FREZITE GROUP
Pedro Pacheco
pedro.pacheco@fmttooling.com



General Manager FMT
[Germany]
Andreas Oesterle
andreas.oesterle@fmttooling.de



General Manager Frezite SRO
[Czech Republic]
Vrba Pavel
vrba@frezite.cz



General Manager FMT
[Spain]
Emilio Agraz
emilio.agraz@fmttooling.com



General Manager FMT
[United Kingdom]
Martin Johnson
martin.johnson@fmttooling.co.uk



General Manager FMT
[Poland]
Bartłomiej Augustyniak
bau@fmttooling.pl



General Manager Frezite, Ltda.
[Brazil]
Renato Ferreira
renato.ferreira@frezite.com



General Manager FMT
[Mexico]
Rodin Delgado
rodin.delgado@fmttooling.com



General Manager FMT
[Romania]
Florin Muresan
florin.muresan@fmttooling.com



MEXICO



UNITED KINGDOM



CZECH REP.



BRAZIL



GERMANY



POLAND



PORTUGAL



SPAIN



ROMANIA



GLOBALLY WELL POSITIONED

FREZITE Group

2012

Annual turnover

2013

Annual turnover expected



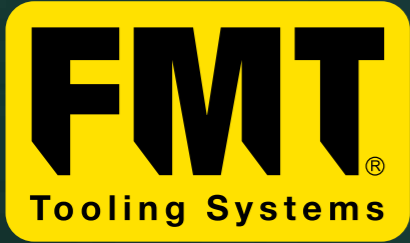

A touch of innovation based

on experience

MISSION

“TO BE AN ORGANIZATION
RECOGNIZED FOR ITS
EFFICIENCY IN MAINTAINING
AND CREATING VALUE.”

VISION

“TECHNOLOGY DEVELOPMENT
FOR SUSTAINABLE
IMPROVEMENT OF
QUALITY OF LIFE.”

VALUES

“INTEGRITY, TEAM SPIRIT AND INNOVATION.”

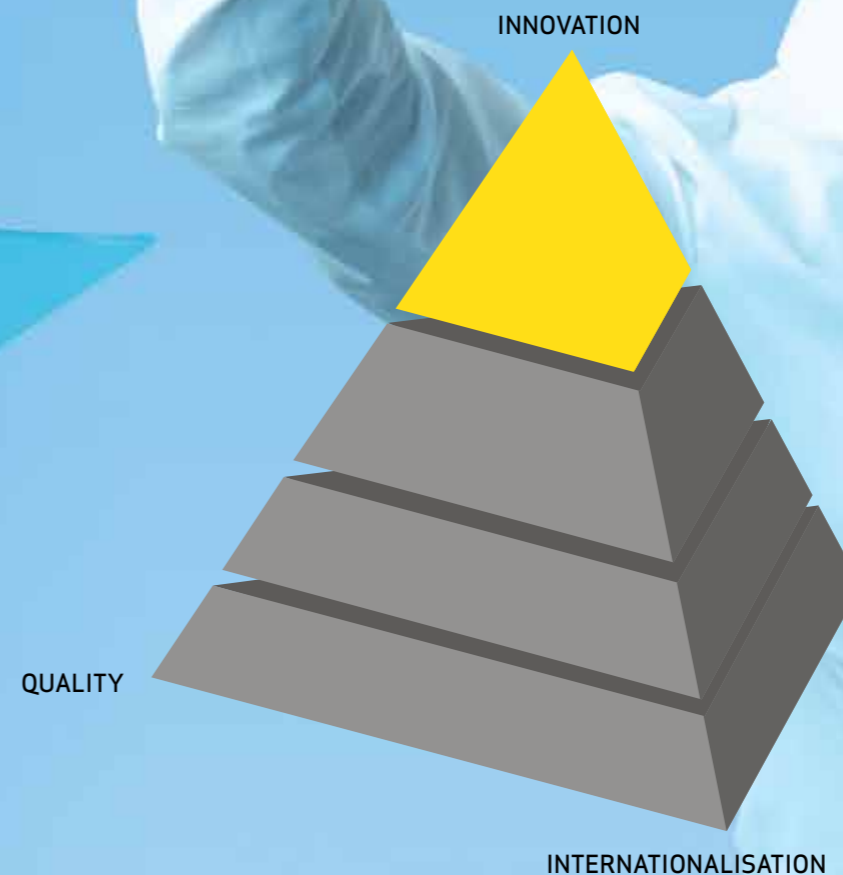

INDUSTRIES/MARKETS



AUTOMOBILE

AERONAUTICS

ELECTRONIC

MEDICAL

MOULDING

VALVES

PHILOSOPHY



Continued investment in the latest machinery technologies

Local support and service for all product

Commitment to research and development

Investment in expertise to support Key User Partnerships

FREZITE Group



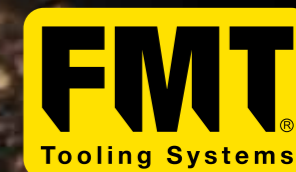

RESEARCH & DEVELOPMENT (CENTRE)

Internal test centre for new cutting tool designs.

Setting up of machining demonstrations for customers.

Troubleshooting of machining problems.

Development of new machining processes and internal knowledge.

The Power of Engineering



FMT 7 Advantages



Ideal Partners



Easy to Work With



Dynamic Team



Enlarged portfolio



Research & Development



Focus on Performance



Global Presence





Your goals are our goals!

**Feeling our customers challenges
that is part of the solution.**

**Impossible is not listed
on our glossary.**

**“WE ARE PART OF OUR
CUSTOMERS TEAM.”**



**“WE KNOW HOW TO LISTEN
OUR CUSTOMERS.”**

We have expertise to understand your challenges and goals, together we will develop the best solution.

**“ALWAYS LOOKING FOR
THE RIGHT SOLUTION.”**

Flexibility and innovation

Enlarged portfolio

The best quality

The best cost effectiveness

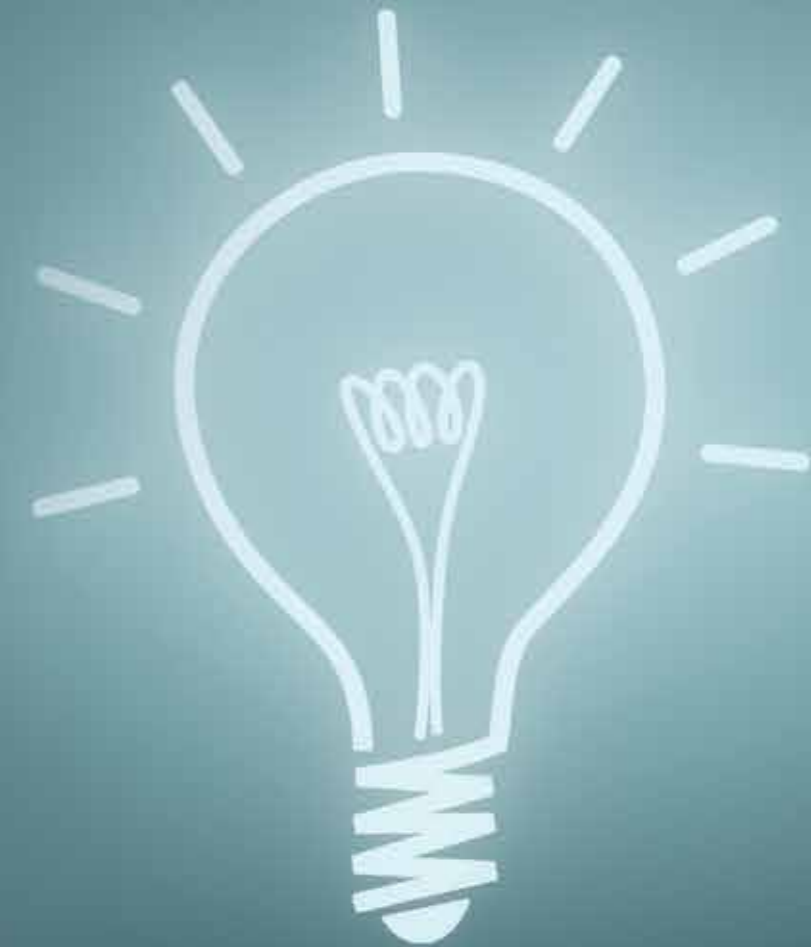

**“WE WANT TO BE THE BEST,
NOT THE BIGGEST.”**

Proximity, efficiency and a speed response are advantages which make working **with us unique and easy.**



Our commitment, delivery and products

- ✓ Solid carbide – 3 to 4 weeks
- ✓ Braze carbide – 4 to 5 weeks
- ✓ Indexable tooling – 4 to 5 weeks
- ✓ PCD milling cutter – 4 to 5 weeks
- ✓ PCD drills – 4 to 5 weeks
- ✓ Fine boring tools – 6 weeks
- ✓ Modular systems – 6 weeks
- ✓ Inserts – 4 weeks
- ✓ Service – 3 weeks
- ✓ Follow up order, less one week



Special service

- ✓ Offers in 48 hours max
- ✓ Local technical support in 24 hours
- ✓ Special delivery from 2 to 10 working days
- ✓ Project offers in 2 weeks max



**Urgent
Tools**

DYNAMIC
*Flexibility and speed
are part of our
corporate philosophy.*

**Vending
Machine**

**Consignment
stock at customer**



GEARBOX INDUSTRY

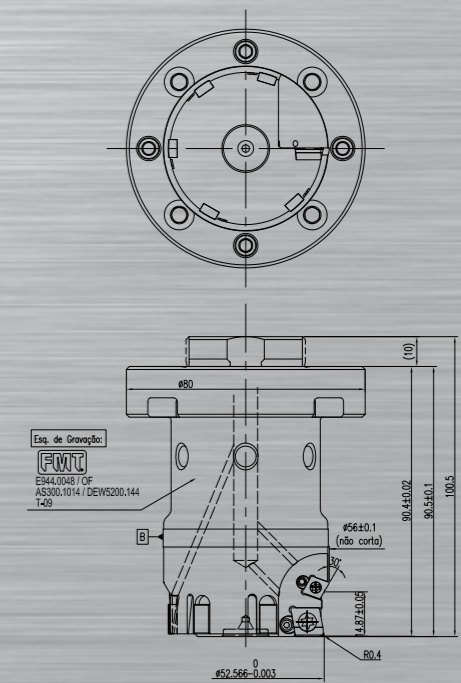
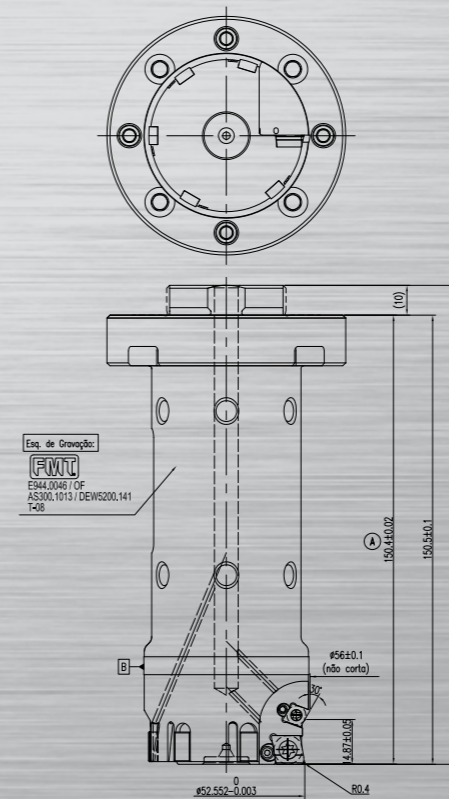
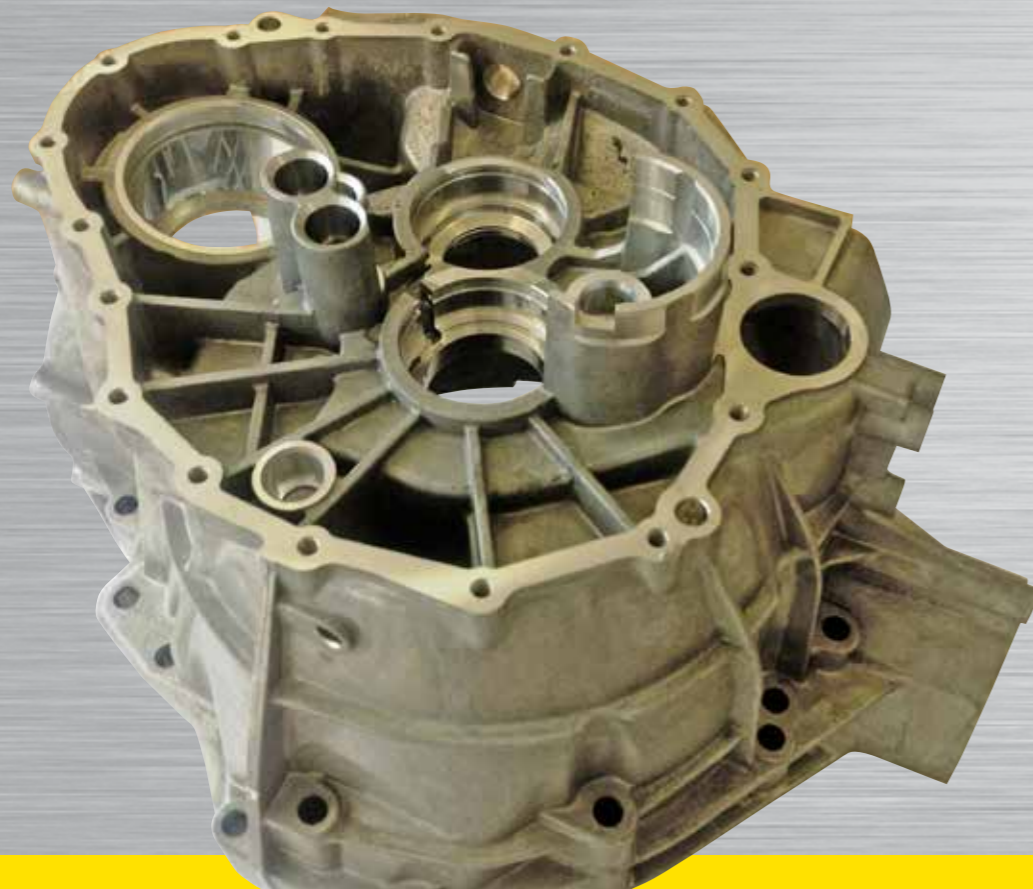
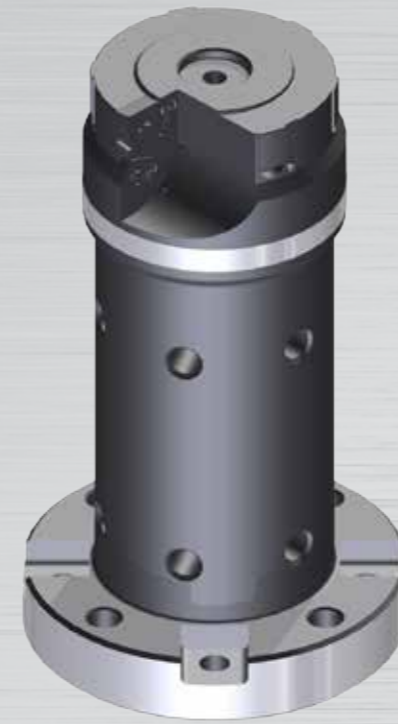
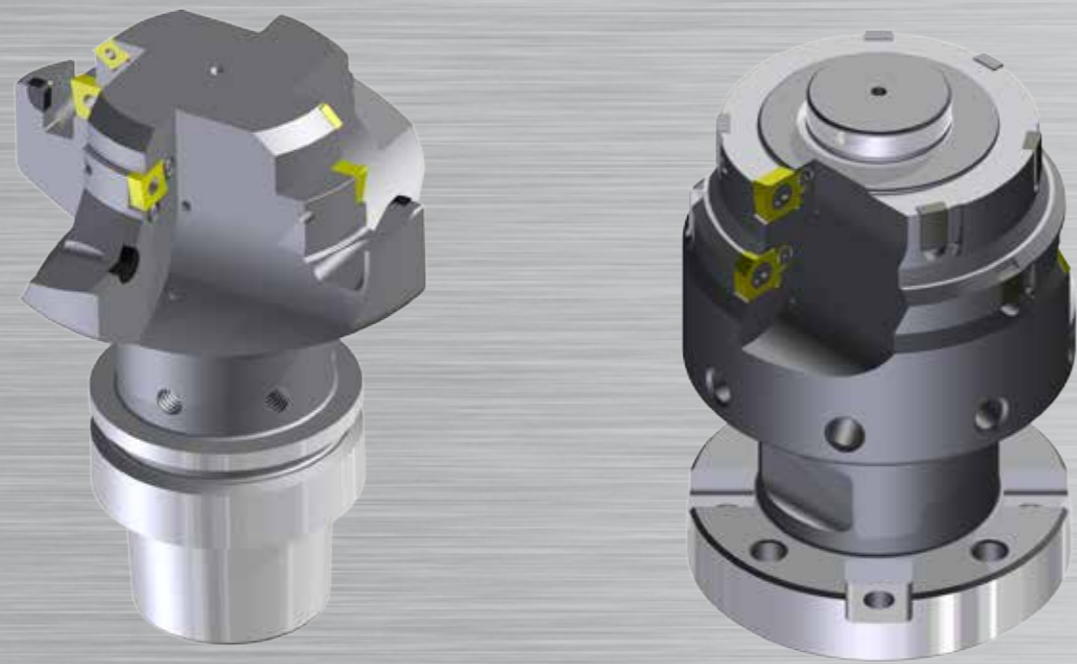

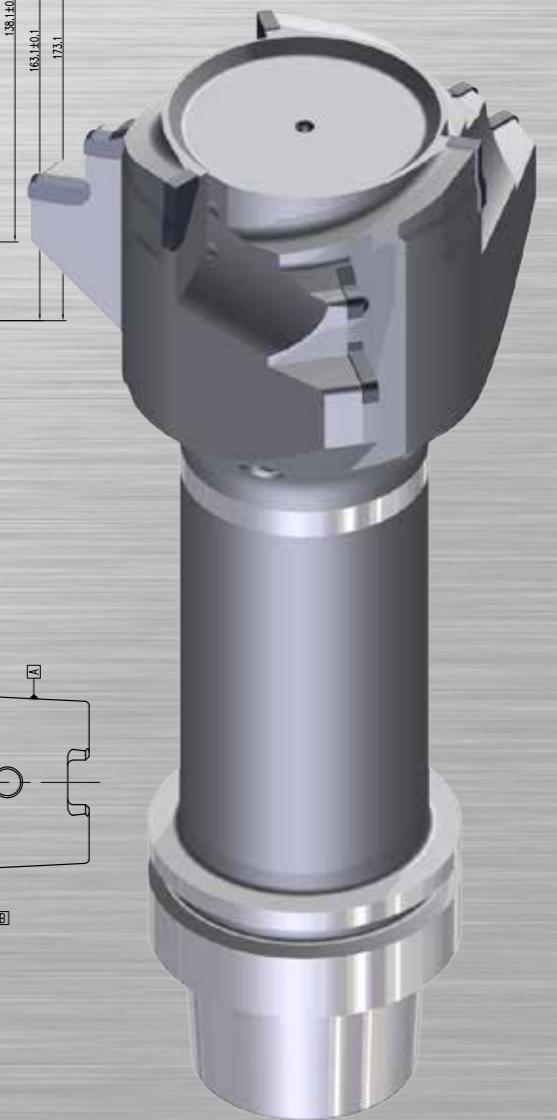
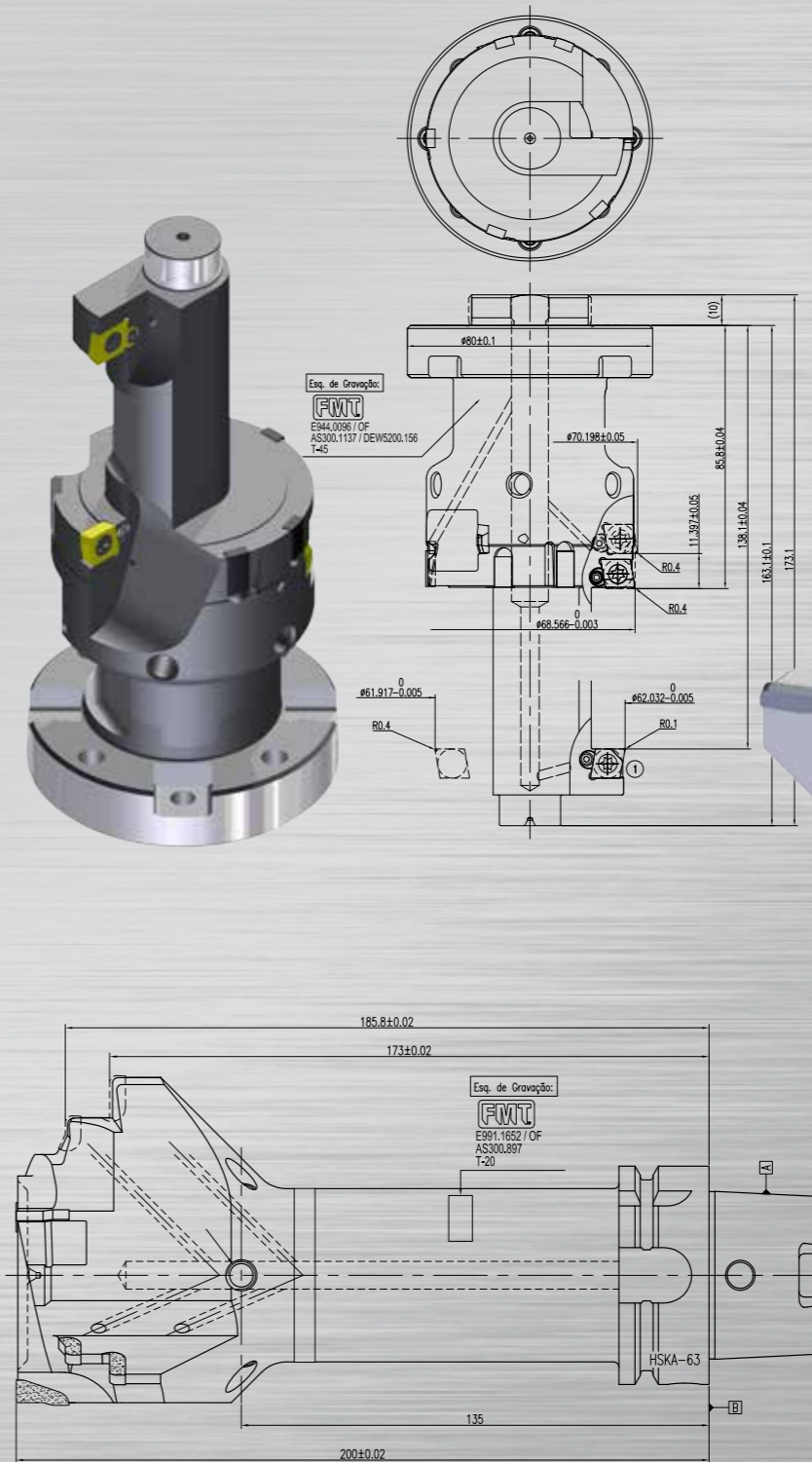

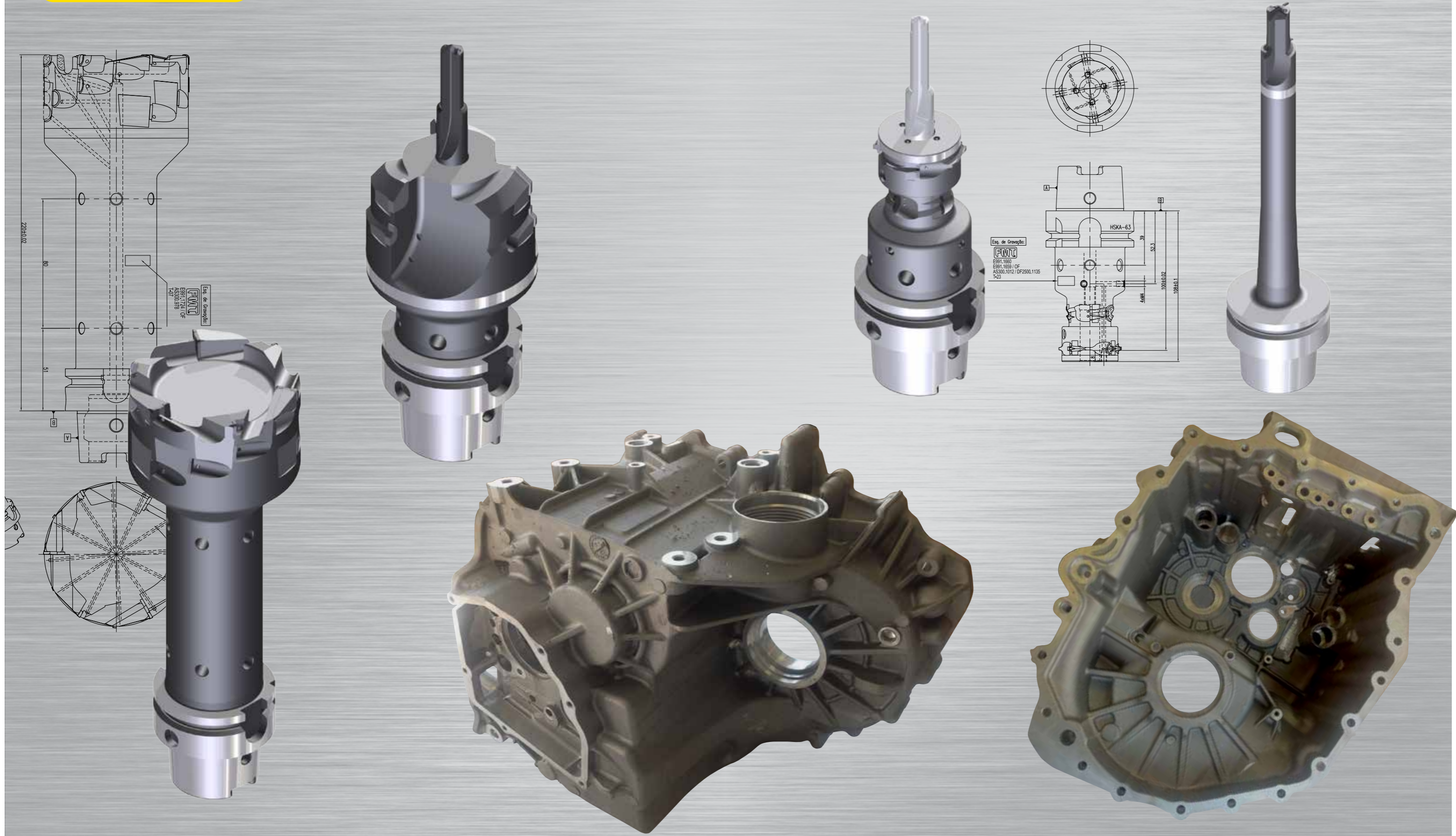

PORTFOLIO



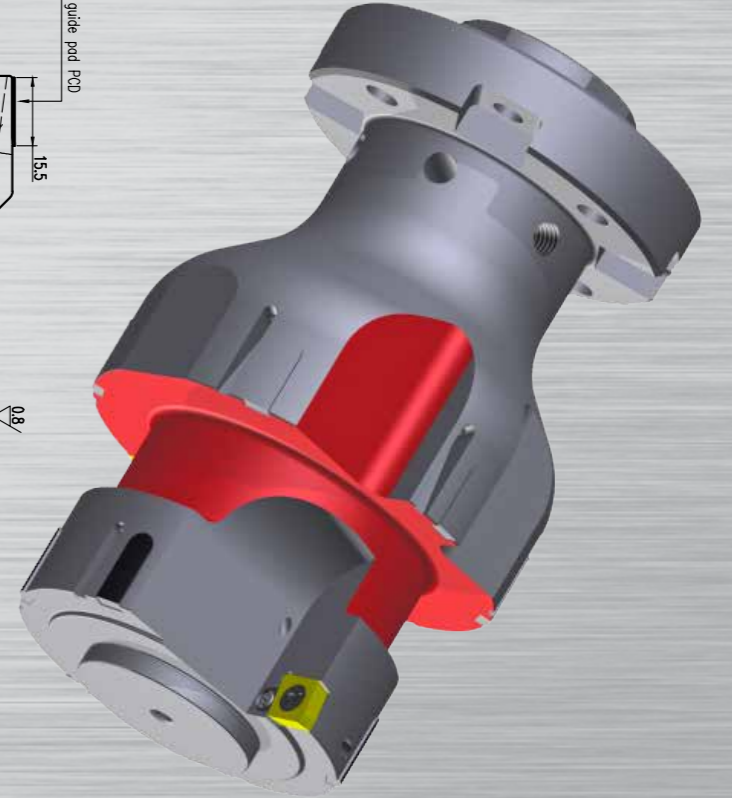
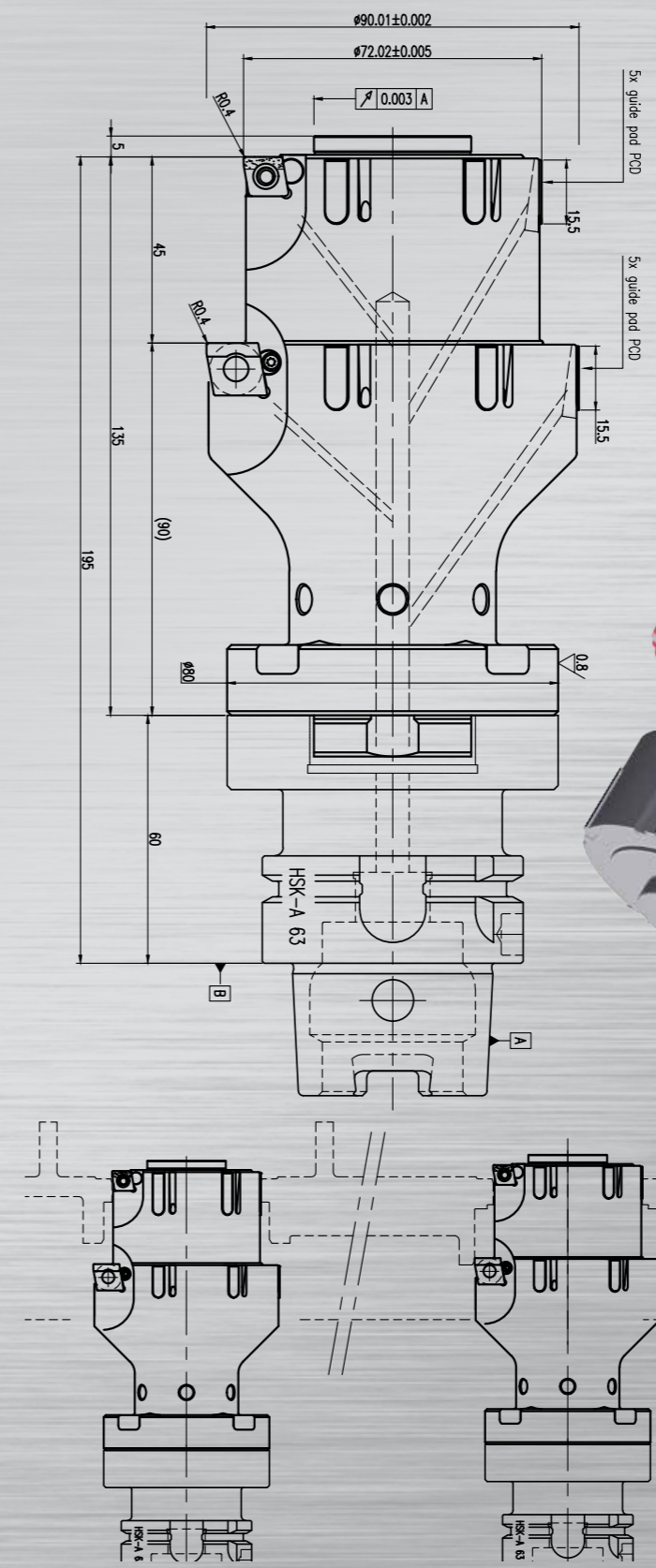
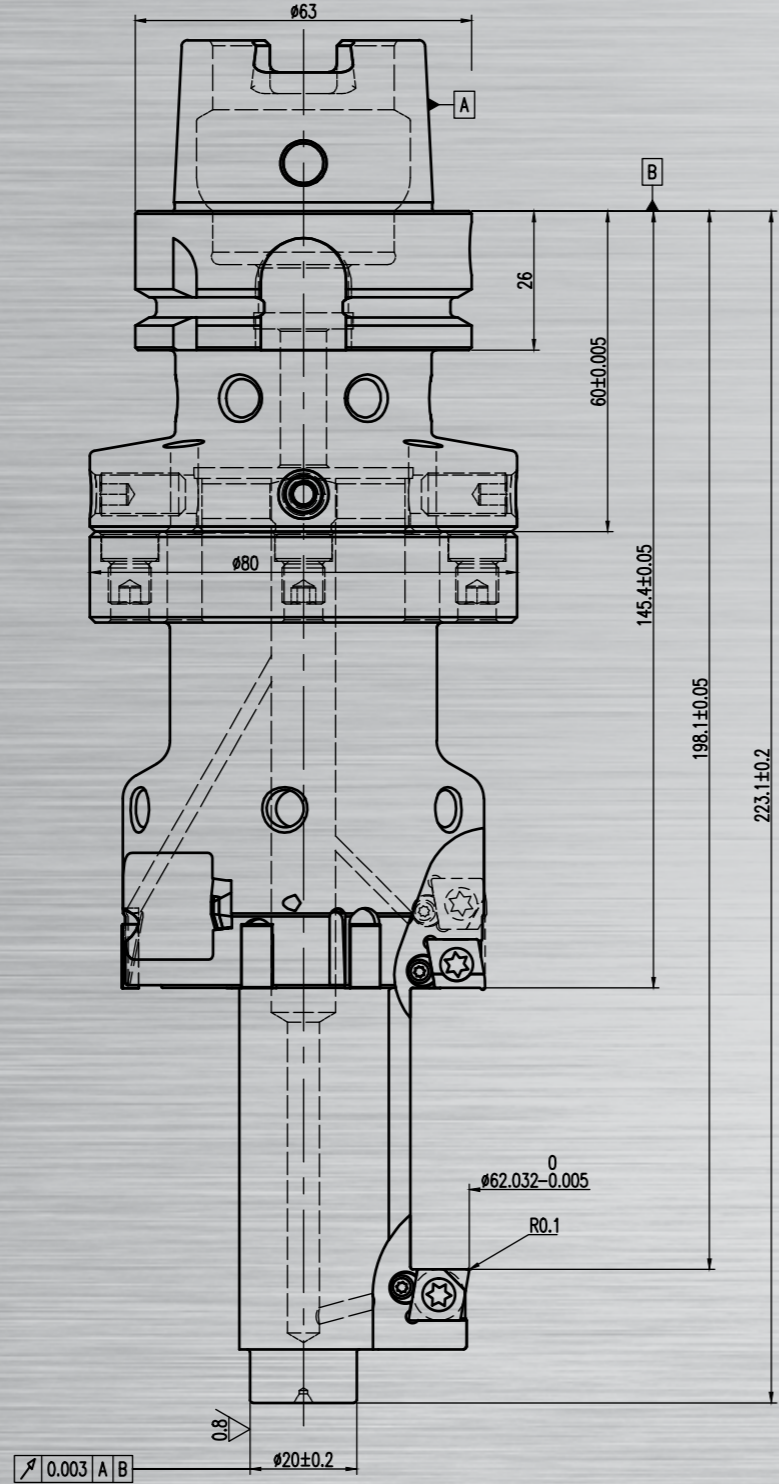
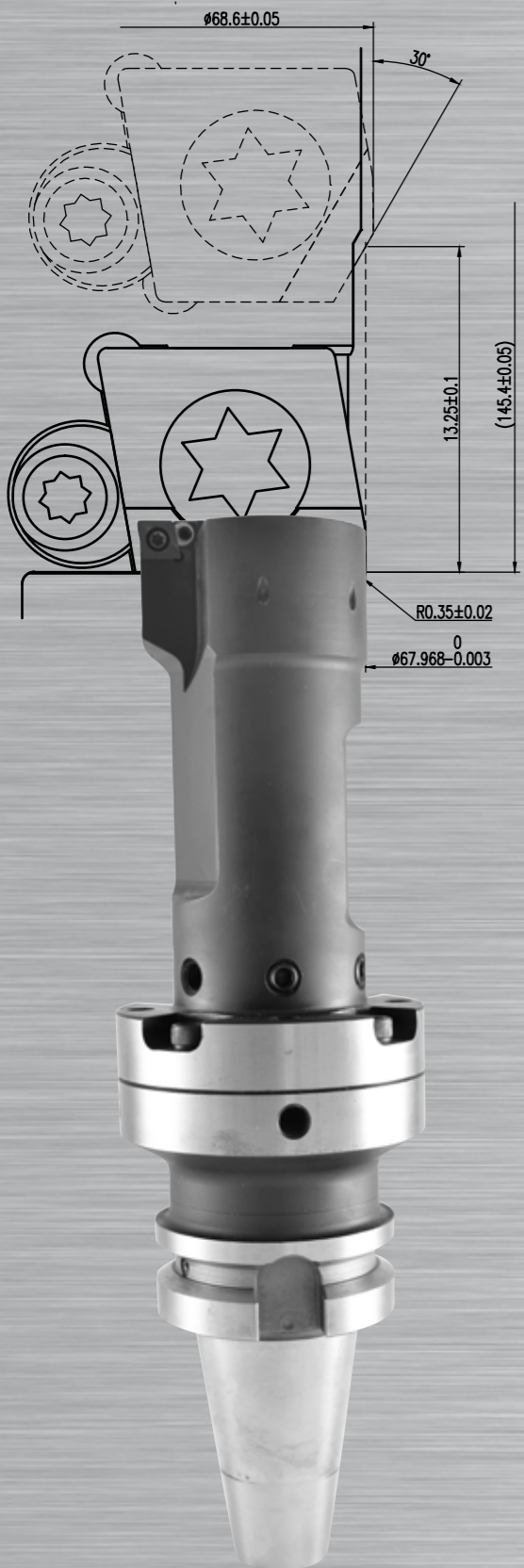

Dwg: CE31089
Section A-A
Finishing tool

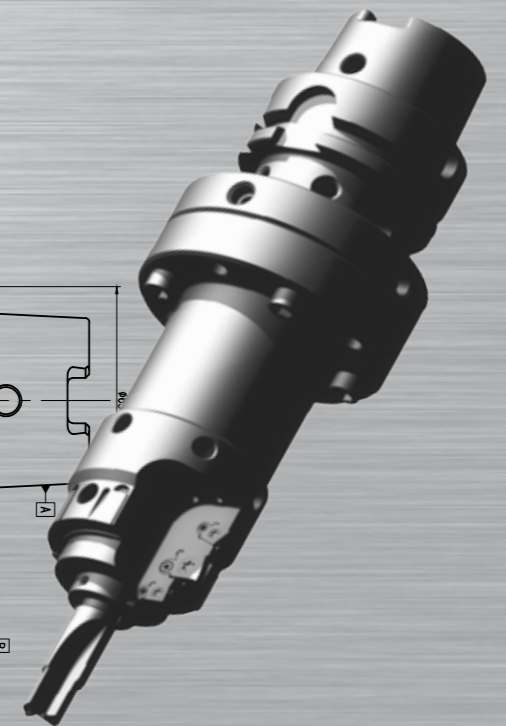
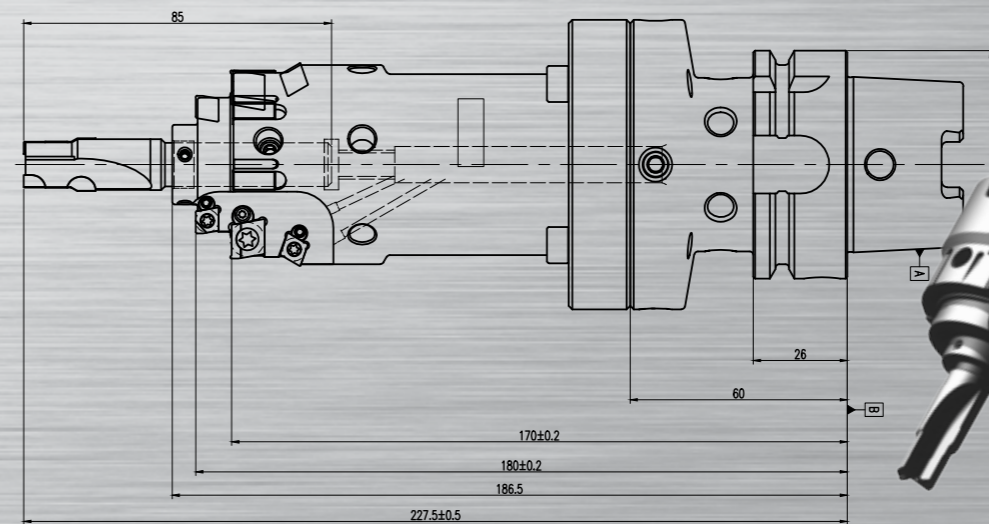
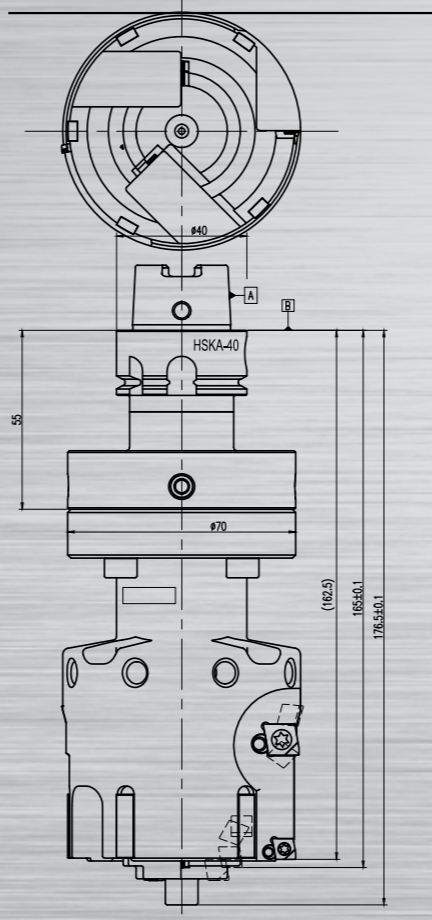
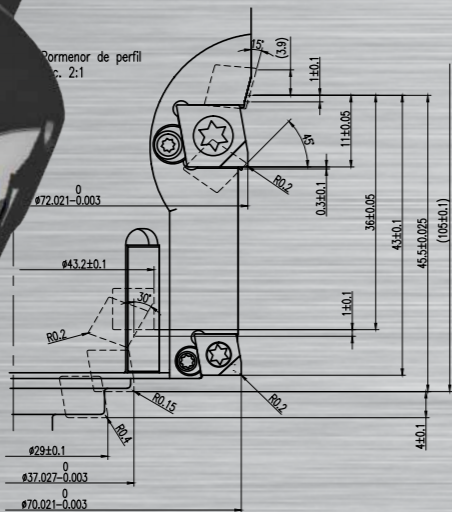
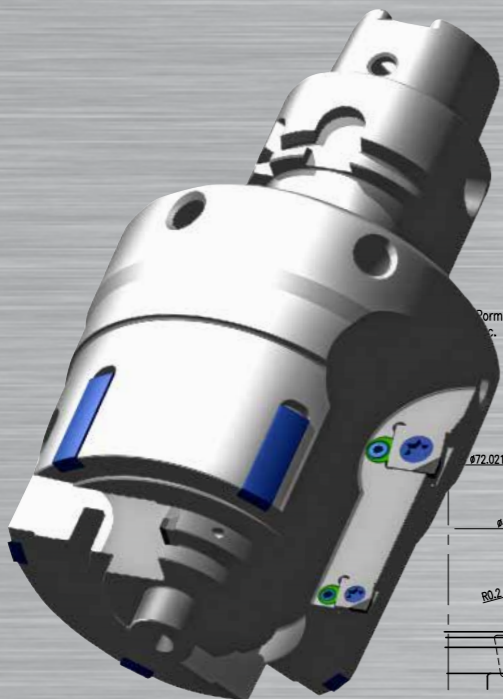
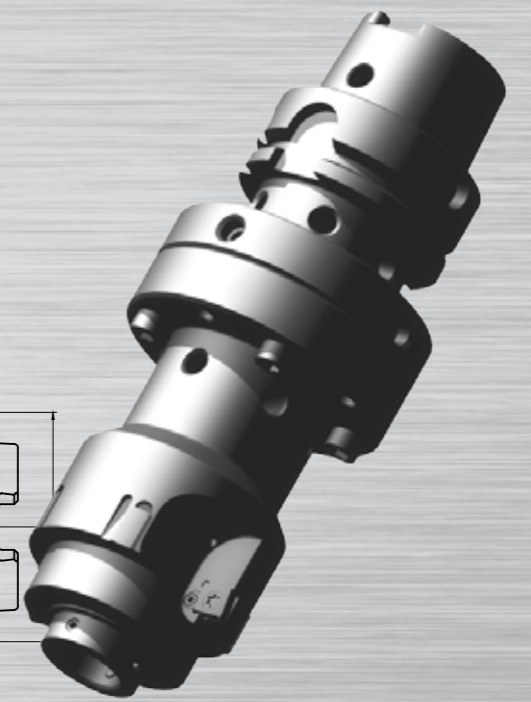
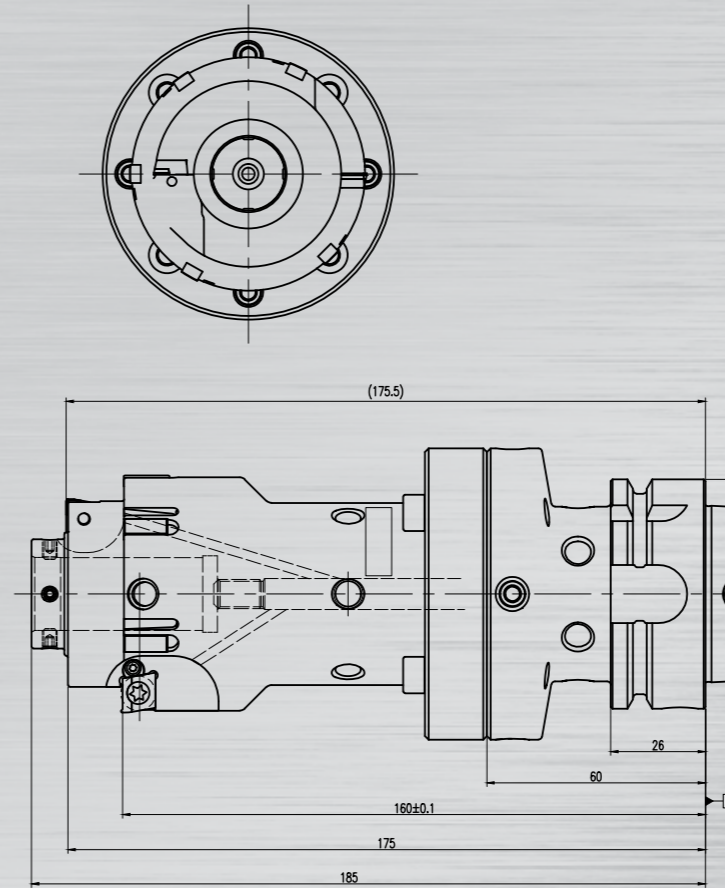
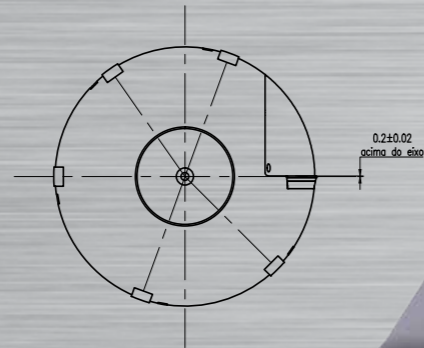
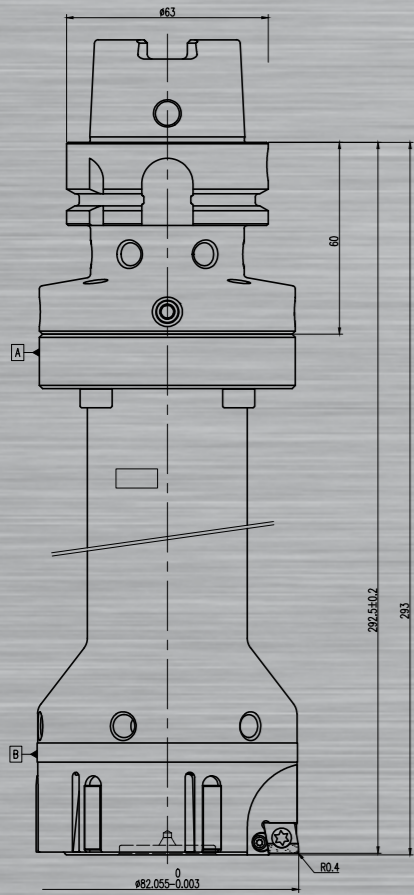

Technical drawing of a tool holder (E975.0047) showing front, side, and top views. Dimensions include diameters of 63, 100, 155.02±0.005, and 188.4±0.2, and lengths of 15, 180±0.2, and 188.4±0.2. A detail view shows a chamfered edge with R0.4 and a diameter of 1.4±0.1. The drawing includes a table of specifications and a revision table.

CCW 081304 (pastilha padrão)
CCW 062002 (pastilha padrão)
SCM 120406 (N6.00764 não fornecer)
M2.5
M4
M5

Qt.	Designação	Nº.	Desenho Nº	Materiais	Observações

Nº.	Alteração	Data	Nome	Proj. Europ.	Data	Nome

Nome: **ento E975.0047**

Substituído: _____

Technical drawing of a tool holder (E975.0073) showing front, side, and top views. Dimensions include diameters of 63, 100, 155.02±0.005, and 188.4±0.2, and lengths of 15, 180±0.2, and 188.4±0.2. A detail view shows a chamfered edge with R0.4 and a diameter of 1.4±0.1. The drawing includes a table of specifications and a revision table.

CCW 081304 (pastilha padrão)
CCW 062002 (pastilha padrão)
SCM 120406 (N6.00764 não fornecer)
M2.5
M4
M5

Qt.	Designação	Nº.	Desenho Nº	Materiais	Observações

Nº.	Alteração	Data	Nome	Proj. Europ.	Data	Nome

Nome: **ento E975.0073**

Substituído: _____

Technical drawing of a tool holder (E975.0066) showing front, side, and top views. Dimensions include diameters of 63, 100, 155.02±0.005, and 188.4±0.2, and lengths of 15, 180±0.2, and 188.4±0.2. A detail view shows a chamfered edge with R0.4 and a diameter of 1.4±0.1. The drawing includes a table of specifications and a revision table.

CCW 081304 (pastilha padrão)
CCW 062002 (pastilha padrão)
SCM 120406 (N6.00764 não fornecer)
M2.5
M4
M5

Qt.	Designação	Nº.	Desenho Nº	Materiais	Observações

Nº.	Alteração	Data	Nome	Proj. Europ.	Data	Nome

Nome: **Broca #35x130 DP Z1+1+1+1+1 E975.0066**

Substituído: _____

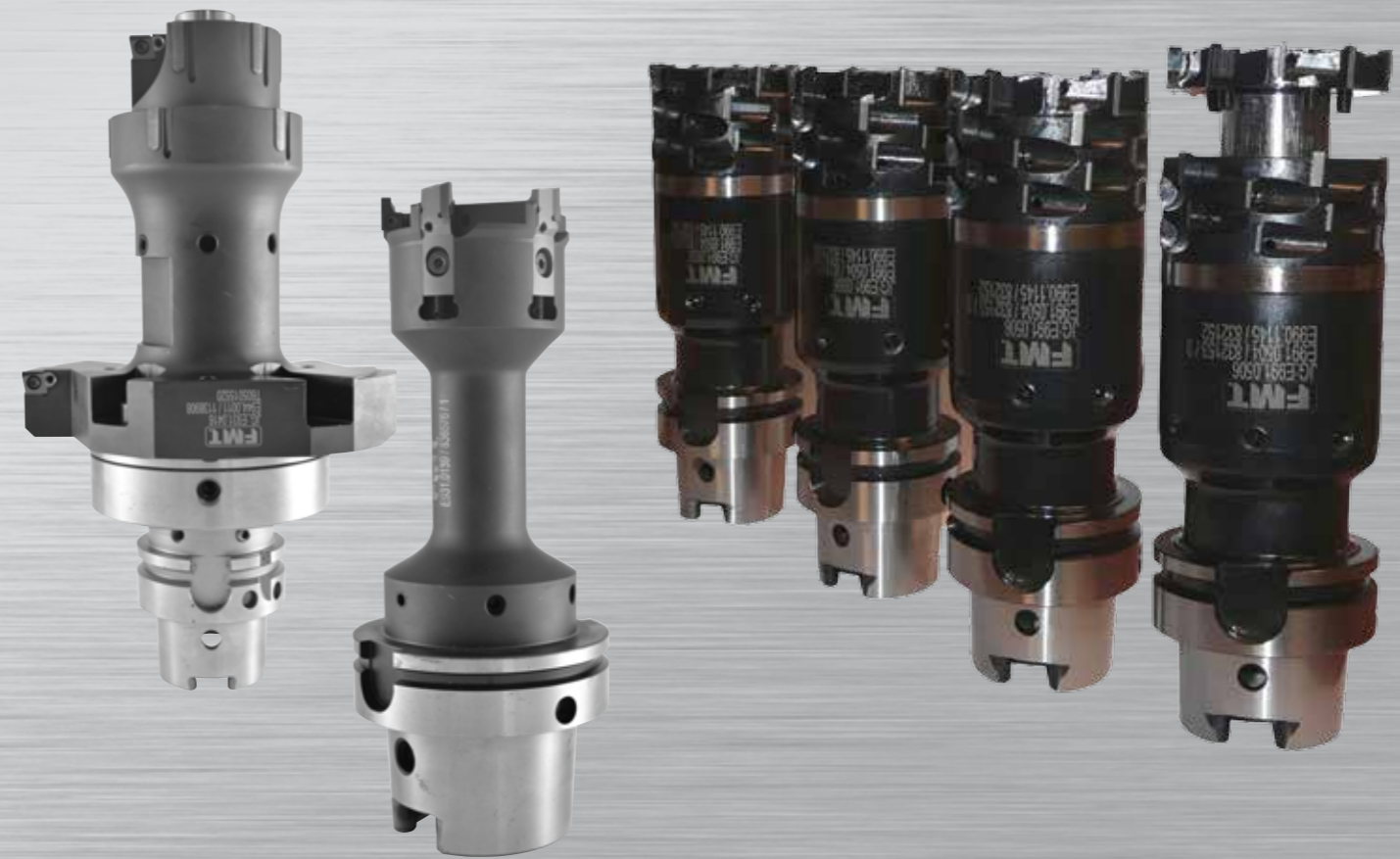

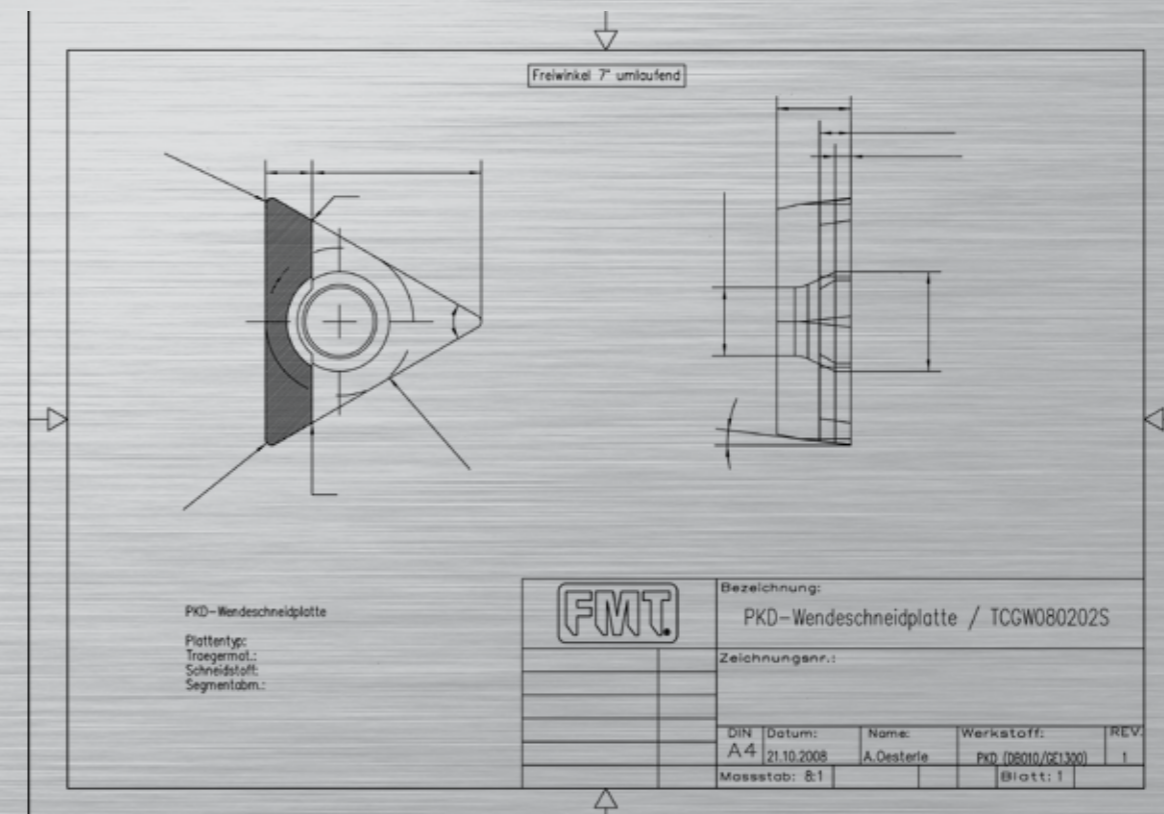
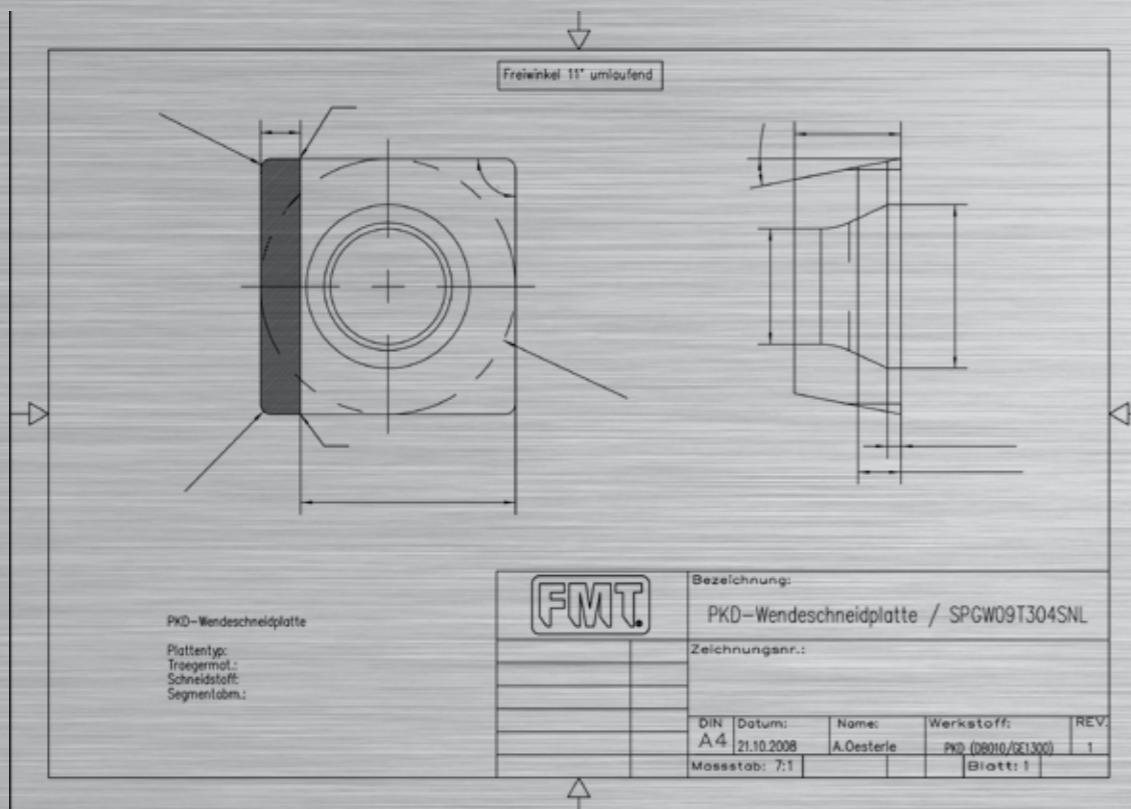
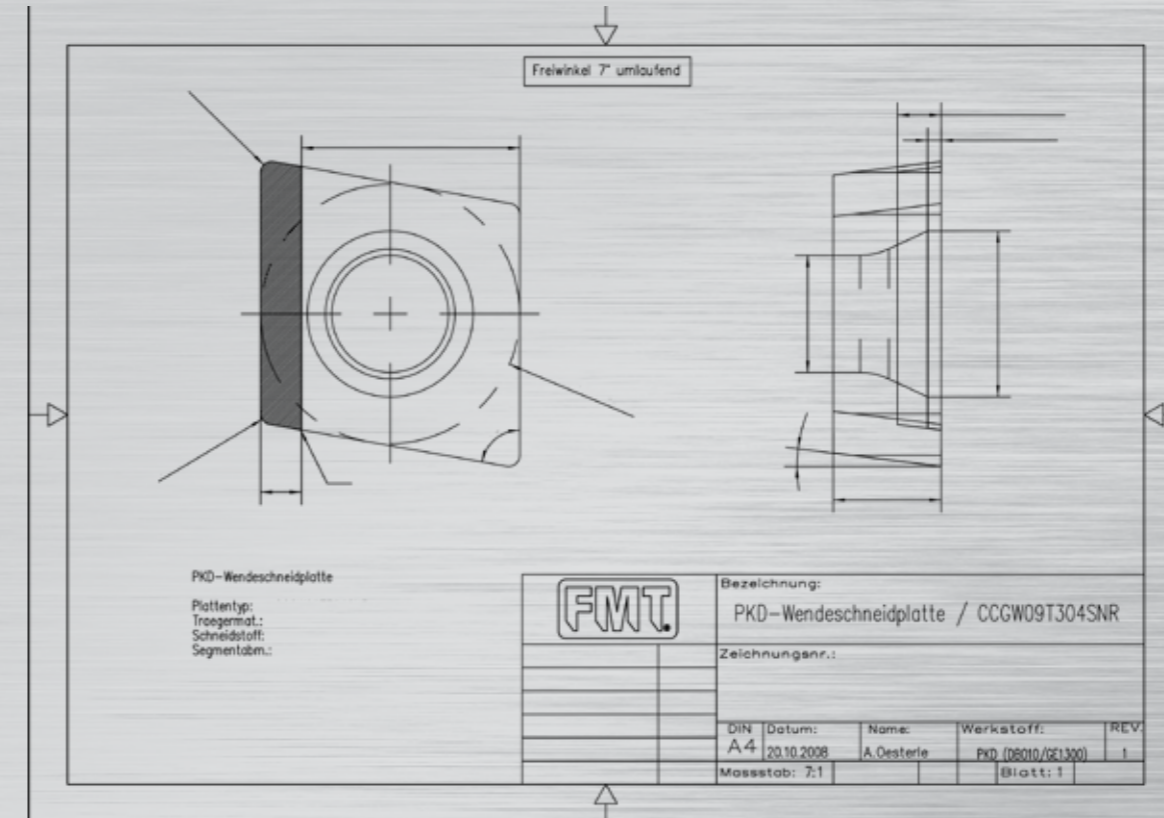
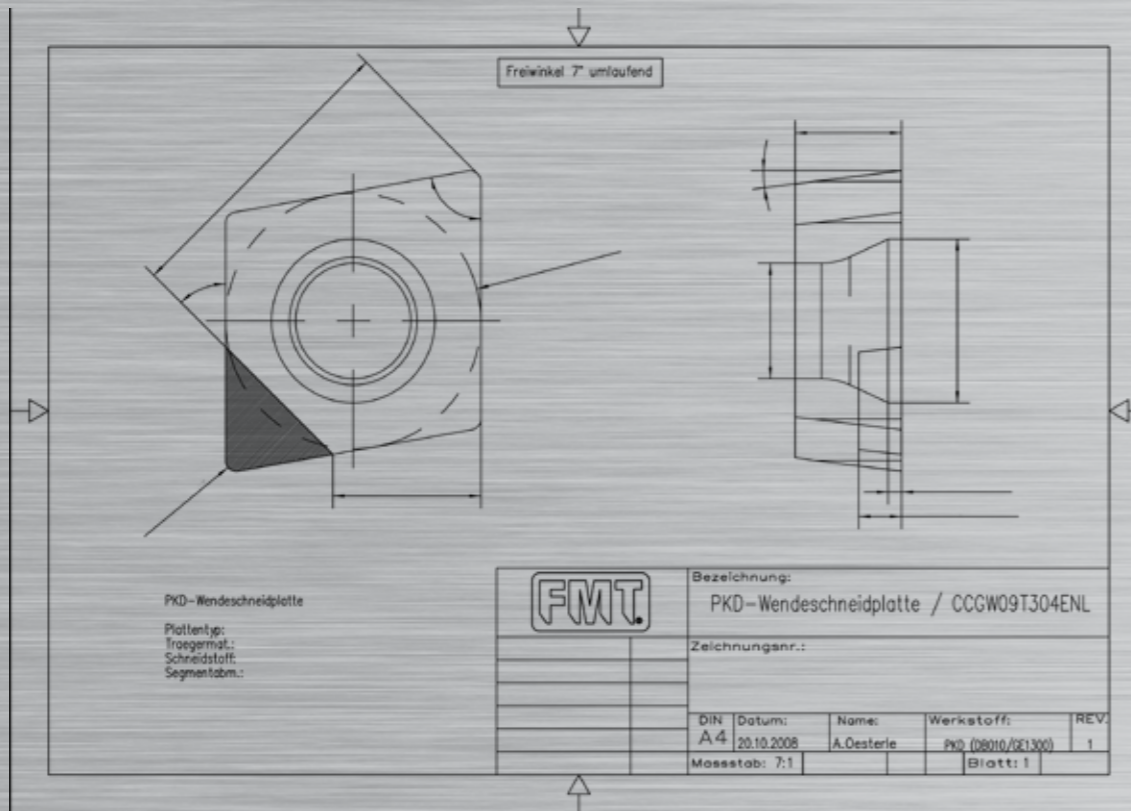

R&D

NEW DEVELOPMENT

THE EFFECTIVENESS OF THE SOLUTIONS PRESENTED BY FMT IS AN ADDED BONUS FOR THE CUSTOMER.

BY CUTTING YOUR BUSINESS OPERATING COSTS, WE INCREASE YOUR PRODUCTIVITY.

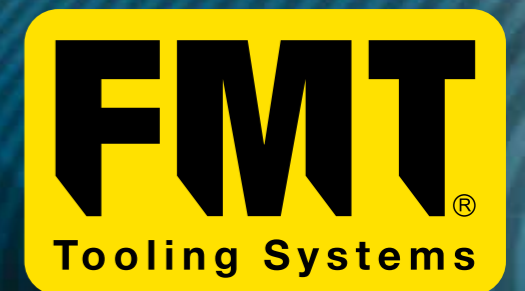
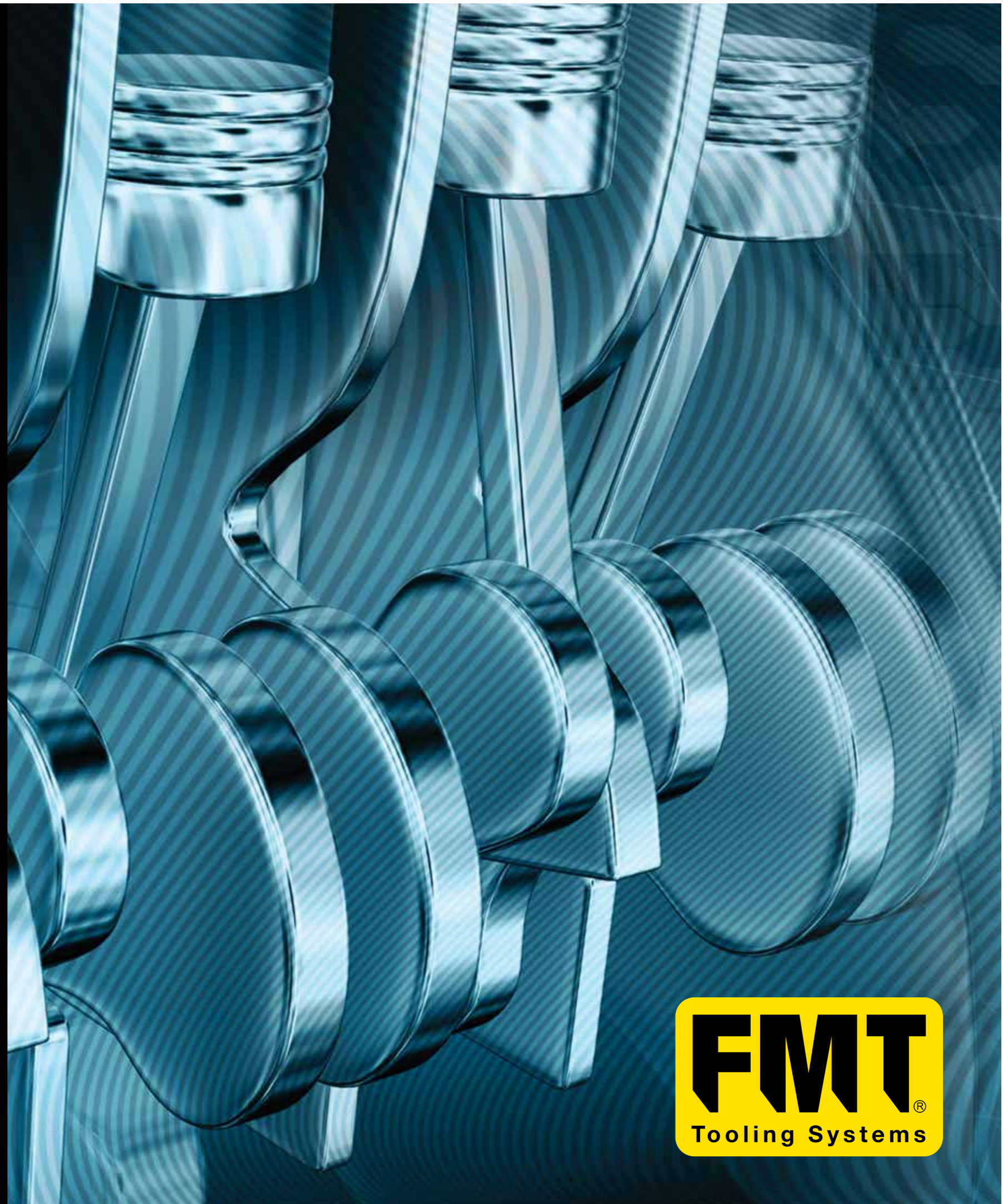

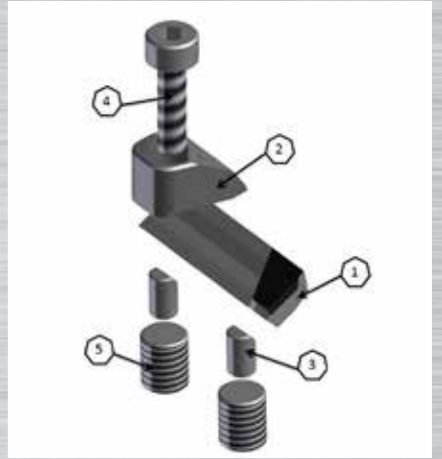
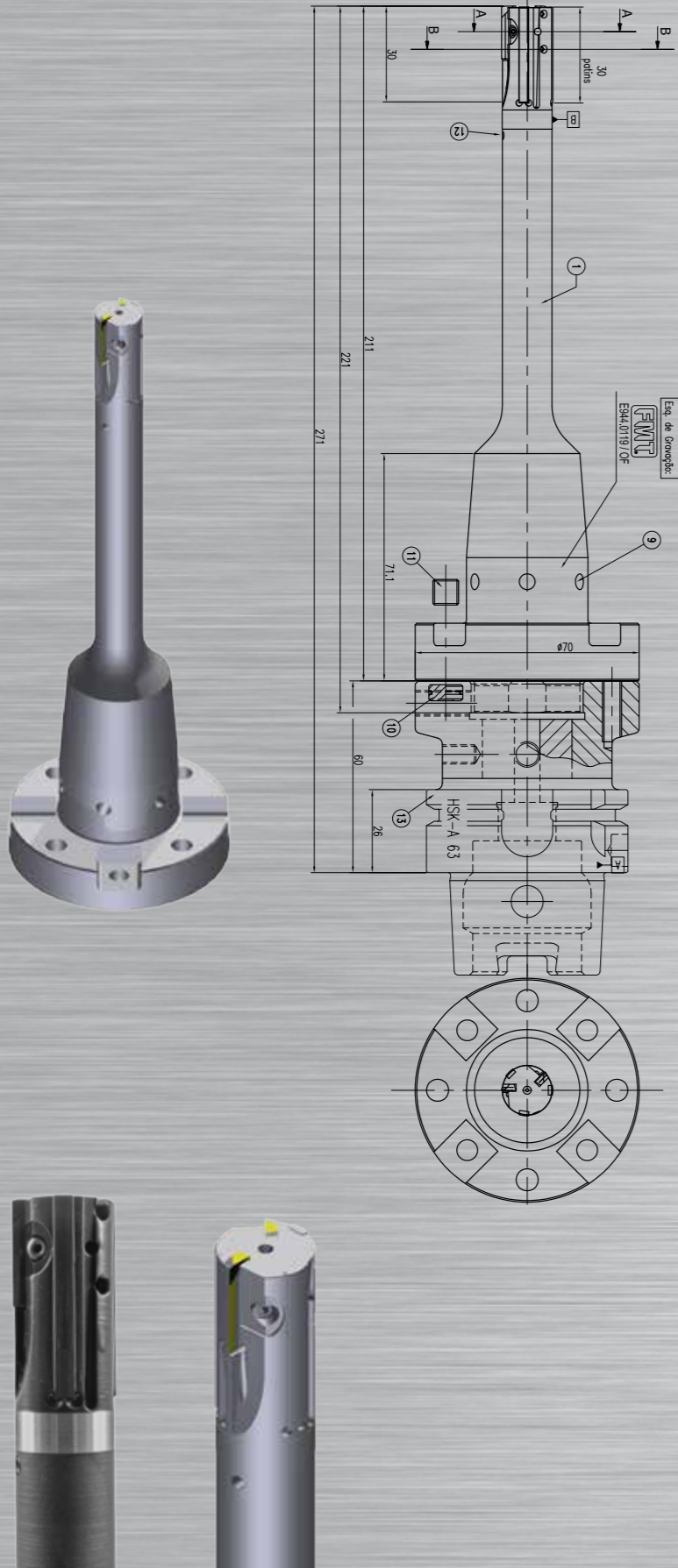



We turn challenges into technologies for the future.

FREZITE Group

PT Head Office:
FREZIGEST, SGPS, SA
Rua do Vau, 173 · Apartado 134
4786-909 Trofa
T. +351 252 400 360
F. +351 252 417 254
www.frezitegroup.com

PT FREZITE – Ferramentas de Corte, SA
Rua do Vau, 173 · Apartado 134
4786-909 Trofa
T. +351 252 400 360
F. +351 252 417 254
info@frezite.com
www.frezite.com

PT FREZITE – Ferramentas de Corte, SA (FMT)
Rua do Vau, 201 · Apartado 134
4786-909 Trofa
T. +351 252 400 360
F. +351 252 103 279
info@fmttooling.com
www.fmttooling.com

PT FREZITE – Equipamentos Energéticos
& Ambiente, Lda.
Rua do Vau, 323 · Apartado 134
4786-909 Trofa
T. +351 252 400 360
F. +351 252 401 014
energia@frezite.com
www.energia.frezite.com

PT FREZITE – Ferramentas de Corte, SA
(MF Metal)
Rua do Vau, 201 · Apartado 134
4786-909 Trofa
T. +351 252 103 277
F. +351 252 103 278
pedidos@mfmetal.net
www.mfmetal.net



ES FREZITE – Herramientas de Corte, SL
Polígono Ind. Virgen de la Salud, 8-A
P.O. Box 78
46950 Xirivella (Valencia)
T. +34 963 135 131
F. +34 963 796 810
info.es@frezite.com
www.frezite.com

ES Frezite Metal Tooling, SL
Polígono Ind. Virgen de la Salud, 8-A
P.O. Box 78
46950 Xirivella (Valencia)
T. +34 686 417 613
F. +34 963 134 484
info.es@fmttooling.com
www.fmttooling.com

BR FREZITE – Ferramentas de Corte, Ltda.
Rua Otto Emilio Beckert, 85-C
Boehmerwald · São Bento do Sul
SC CEP: 89287-665
T. +55 (47) 3635 2065/66
F. +55 (47) 3635 2067
comercial.brasil@frezite.com
www.frezite.com.br

FI Teratoimitus Salonen Oy
Vipusenkatu 17
15230 Lahti
T. +358 207 999 862
F. +358 207 999 868
jarmo.lehtinen@teratoimitus.fi
www.teratoimitus.fi

CZ FREZITE, s.r.o.
Textilní 1278
506 01 Jičín
Czech Republic
T. +420 491 513 97- 0/1/2/3
obchod@frezite.cz
www.frezite.cz

DE FMT – Frezite Metal Tooling, GmbH
Lange Straße 66
72336 Balingen
T. +49 7433 / 99741-0
F. +49 7433 / 99741-25
info.de@fmttooling.de
www.fmttooling.com

UK Frezite Metal Tooling (UK) LTD
14B Orgreave Close
Handsworth Industrial Estate
Handsworth Sheffield S13 9 NP
T. +44 (0) 1142 693803
F. +44 (0) 1142 540523
enquiries@fmttooling.co.uk
www.fmttooling.co.uk

RO FMT Romania
Calea Turzii, nr 227, Ap 55
Cluj Napoca, Romania
T. +40 731 894 550
info.ro@fmttooling.com
www.fmttooling.com

PL FMT Tooling Systems Sp. z o.o.
ul. Klimasa 4
50-515 Wrocław
T. +48 71 3907571
F. +48 71 3907571
bau@fmttooling.pl
www.fmttooling.pl

MX Frezite Metal Tooling S. de R.L. de C.V.
Calle 16 Sur No. 4312-101
Col. Anzures, Puebla, Pue. C.P. 72530
T. +52 (222) 2 454 875
info.mx@fmttooling.com
www.fmttooling.com